

Service  
Service  
**Service**



# Service Manual

## TABLE OF CONTENTS

	Chapter
Location Of PCBA & Versions Variation .....	1-2
Technical Specification .....	1-3
Safety instruction .....	1-4
Software upgrade instruction .....	2
Trouble Shooting.....	3
Dismantling instructions .....	4
Block Diagram.....	5
Wiring Diagram .....	6
MP3&USB JACK A+B+BT A+B+REMOTE PCB .....	7
MAIN PCB .....	8
VOL&KEY PCB .....	9
MIC JACK PCB .....	10
JACK PCB .....	11
AMP+POWER PCB .....	12
Mechanical Exploded & Packing View .....	13
Revision List .....	14

© Copyright 2014 WOOX Innovations limited.

All rights reserved. No part of this publication may be reproduced, stored in a retrieval system or transmitted, in any form or by any means, electronic, mechanical, photocopying, or otherwise without the prior permission of WOOX Innovations. Philips and the Philips' shield Emblem are registered trademarks of Koninklijke Philips N.V. and are used by WOOX Innovations Limited under license from Koninklijke Philips N.V.

Published by SW\_HF1401

GB 3140 038 61360

Version 1.0

**PHILIPS**



**LOCATION OF PCBA**

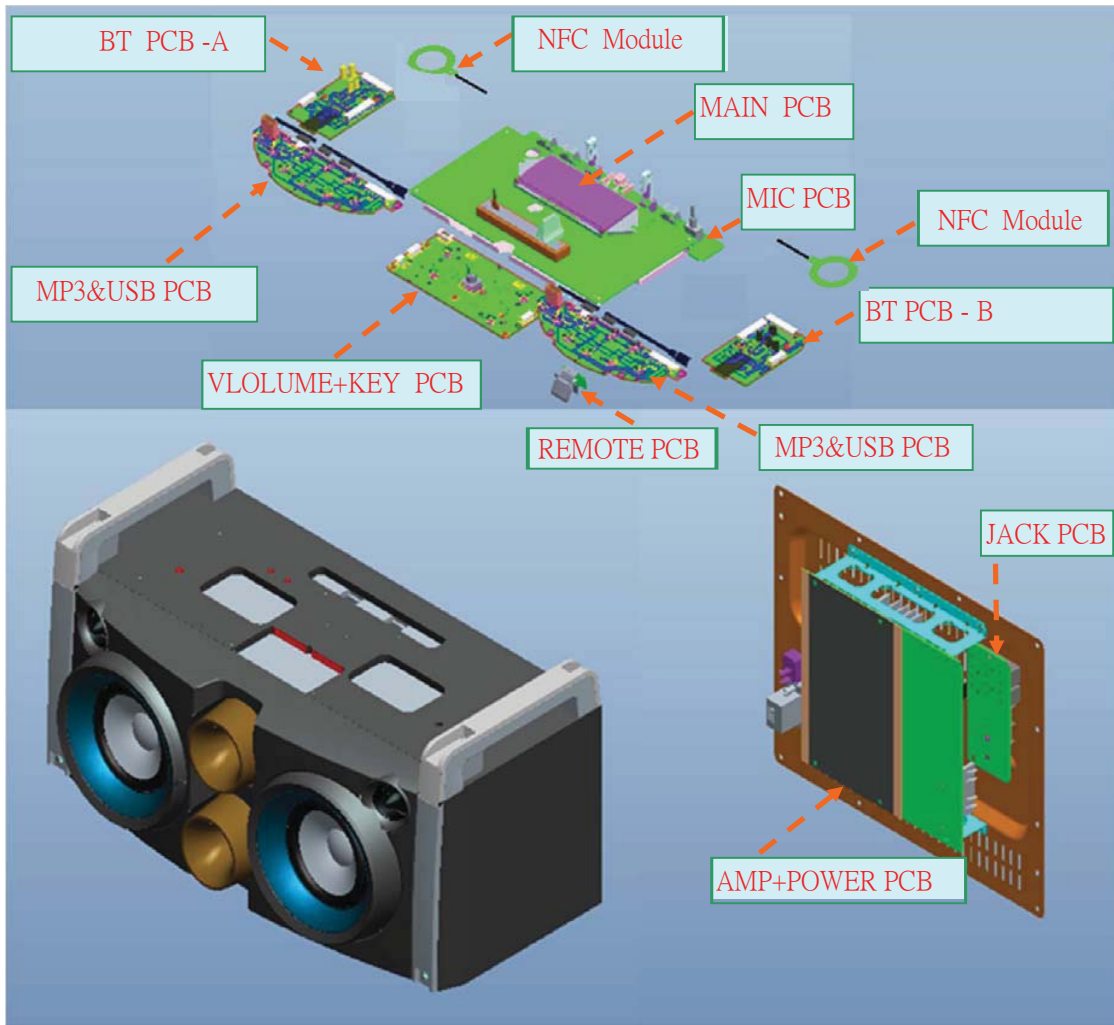

**VERSIONS VARIATION:**

Board in used	Type/Versions		NTRX100	
			/55	/12
MP3&USB JACK A+B+BT A+B+REMOTE Board			C	C
MAIN Board			C	C
VOL&KEY Board			C	M
MIC JACK Board			C	M
JACK Board			C	M
AMP+POWER Board			C	C

\*M= Module Level Repair

\*C = Component Level Repair

## Technical Specification

---

### Amplifier

---

Rated Output Power	380W RMS at 10%THD
Frequency Response	40 - 20000 Hz, $\pm 3$ dB
Signal to Noise Ratio	>65dBA
AUDIO IN	600mV RMS

---

### Tuner (FM)

---

Tuning Range	87.5 - 108MHz
Tuning grid	50KHz
Sensitivity	<22dBf
- Mono, 26dB S/N Ratio	<49.5dBf
- Stereo, 46dB S/N Ratio	
Search Selectivity	<35dBf
Signal to Noise Ratio	>50dB

---

### Speakers

---

Speaker Impedance	4 ohm
Speaker Driver	2 x 160 mm (6.5") woofer + 2 x 50 mm (2") tweeter
Sensitivity	84dB/m/W $\pm$ 4dB/m/W

---

### Bluetooth

---

Bluetooth version	V2.1 + EDR
Frequency band	2.4GHz ~ 2.48GHz ISM Band
Range	10m (free space)
Bluetooth Secure Simple Pairing Using NFC	Yes

---

### General information

---

AC power	110 - 240V~, 50 - 60Hz
Operation power consumption	65W
Eco Standby Power Consumption	<0.5W
Headphone Output	25mW 32ohm
USB direct	Version 2.0/1.1

---

## Safety Instruction

### Important Safety Instructions

- a Do not use this apparatus near water.
- b Clean only with dry cloth.
- c Do not block any ventilation openings. Install in accordance with the manufacturer's instructions.
- d Do not install near any heat sources such as radiators, heat registers, stoves, or other apparatus (including amplifiers) that produce heat.
- e Protect the power cord from being walked on or pinched, particularly at plugs,
- f convenience receptacles, and the point where they exit from the apparatus.
- g Use only with the cart, stand, tripod, bracket, or table specified by the manufacturer or sold with the apparatus. When a cart is used, use caution when moving the cart/apparatus combination to avoid injury from tip-over.



- h Unplug this apparatus during lightning storms or when unused for long periods of time. Refer all servicing to qualified service personnel. Servicing is required when the apparatus has been damaged in any way, such as power-supply cord or plug is damaged, liquid has been spilled or objects have fallen into the apparatus, the apparatus has been exposed to rain or moisture, does not operate normally, or has been dropped.
- i Battery usage CAUTION – To prevent battery leakage which may result in bodily injury, property damage, or damage to the unit:
  - Install all batteries correctly, + and - as marked on the unit.
  - Do not mix batteries (old and new or carbon and alkaline, etc.).
  - Remove batteries when the unit is not used for a long time.
- j Apparatus shall not be exposed to dripping or splashing.
- k Do not place any sources of danger on the apparatus (e.g. liquid filled objects, lighted candles).
- l Where the MAINS plug or an appliance coupler is used as the disconnect device, the disconnect device shall remain readily operable.

### Mains fuse

This information applies only to products with a UK mains plug.

This product is fitted with an approved molded plug. If you replace the fuse, use one with:

- the ratings shown on the plug,
- a BS 1362 approval, and
- the ASTA approval mark.

Contact your dealer if you are not sure about what type of fuse to use.

Caution: To conform with the EMC directive (2004/108/EC), do not detach the plug from the power cord.

Risk of overheating! Never install this apparatus in a confined space. Always leave a space of at least four inches around this apparatus for ventilation. Ensure curtains or other objects never cover the ventilation slots on this apparatus.



#### Warning

- Never remove the casing of this unit.
- Never lubricate any part of this unit.
- Place this unit on a flat, hard and stable surface.
- Never place this unit on other electrical equipment.
- Only use this unit indoors. Keep this unit away from water, moisture and liquid-filled objects.
- Keep this unit away from direct sunlight, naked flames or heat.

## Software upgrade instruction

### 1)Check software version

---

- a) In MP3-LINK mode.
- b) Press < STOP+LEFT+RIGHT+PAUSE/PLAY > and press < UP > or < DOWN > button on RC to show software version information.

### 1)Restore factory setting

---

- a) Press < STOP > button on RC, while display scrolls Firmware version number to reset the device.

### 3) Software Upgrade (Upgrade MCU or CD)

---

- a) Download the latest upgrade software from Philips web.
- b) Rename bin file as "NX1\_CD.BIN" to upgrade CD-A module or CD-B module. Rename hex file as NX1\_MCU.HEX to upgrade MCU module.
- c) Copy the latest upgrade software file into USB storage.
- d) Switch source to USB, and insert your USB device, if you want upgrade MCU, need insert your USB device in side-A USB port.
- e) LCD will show "CD UPG" or "MCU UPG" to indicate have entered upgrade state.
- f) press < OK > or < PAUSE/PLAY > button on panels or RC to start upgrade, then the LCD will show "UPGING" message.
- g) If upgrade CD module, LCD will show "UPG OK" after upgrade complete, if upgrade MCU module, system will enter standby after upgrade complete.

Note:

- 1. One time only upgrade one module.
- 2. Upgrade MCU only via side A USB port and it cannot use side B USB port.
- 3. If upgrade failed, please insert your USB device, and power off the unit, then power on it, and switch source to USB, the system will re-upgrade automatically.

# REPAIR CHART

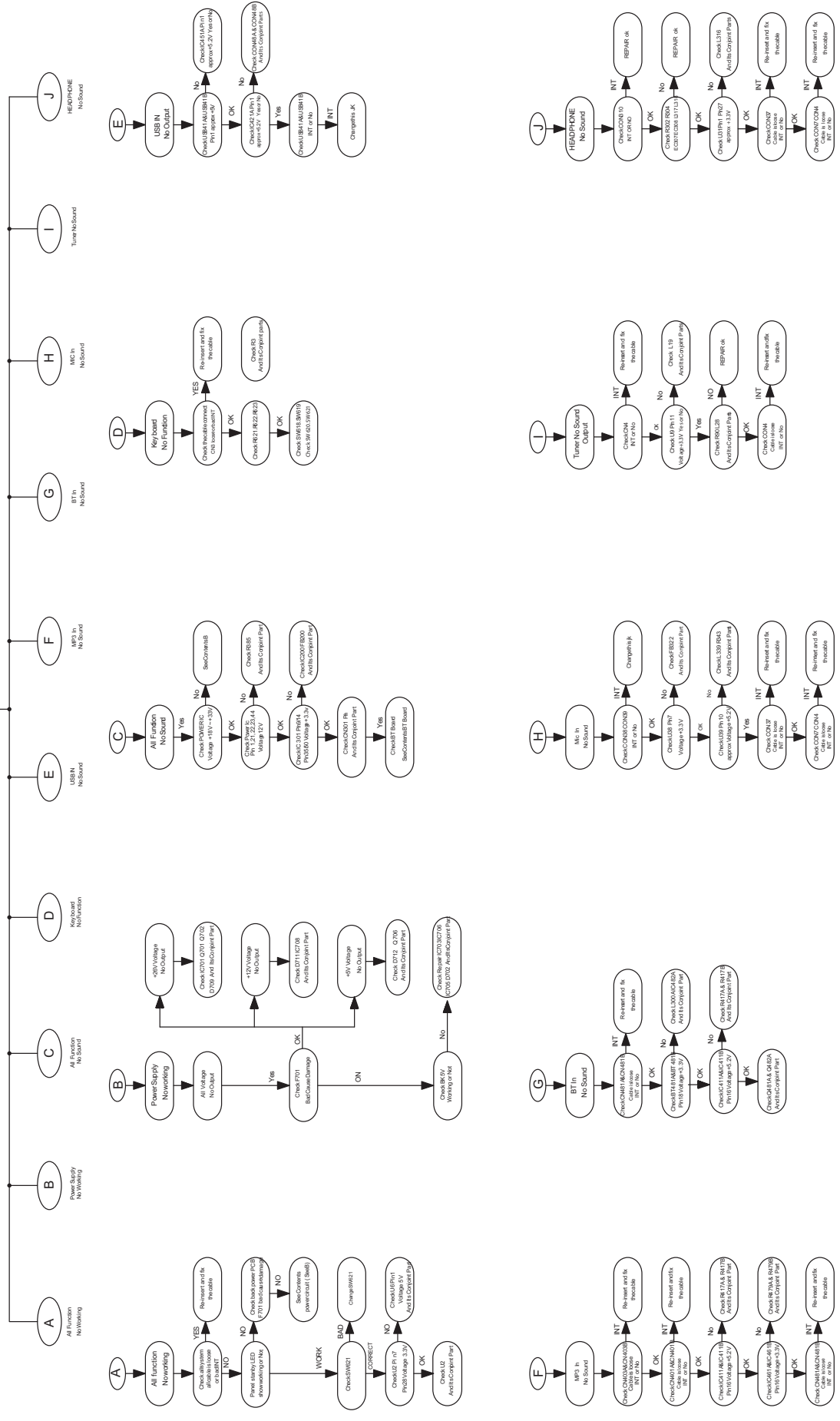

Note: In some service positions the components or copper patterns of one board may risk touching its neighbouring pc boards or metallic parts. To prevent such short-circuit use a piece of hard paper or other insulating material between them.

**Dismantling Instructions**

**Dismantling of the back panel assembly**

- 1) Loosen 12 screws "A" at the back panel as shown in figure 1.

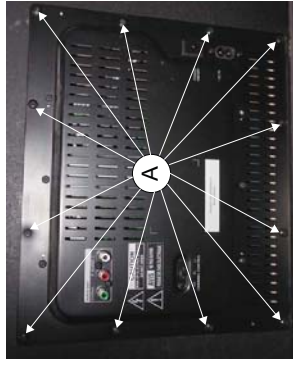

Figure 1

**Dismantling of the AMP & POWER Board**

- 1) Loosen 6 screws "B" on the AMP & Power board as shown in figure 2.

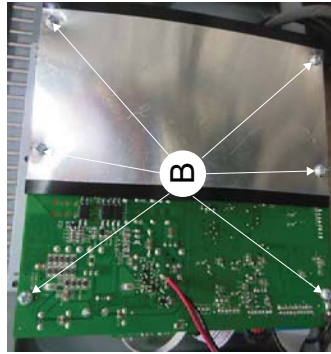

Figure 2

**Dismantling of the JACK Boards**

- 1) Loosen 4 screws "C" at the back panel as shown in figure 3.

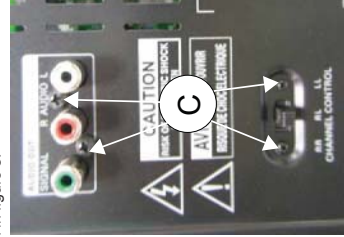

Figure 3

**Dismantling of the top cover**

- 1) Loosen 4 screws "D" at the top cover as shown in figure 3.
- 2) Remove Display Lens & PCCUT sheet then Loosen 5 screws "E" as shown in figure 4 .



Figure 3

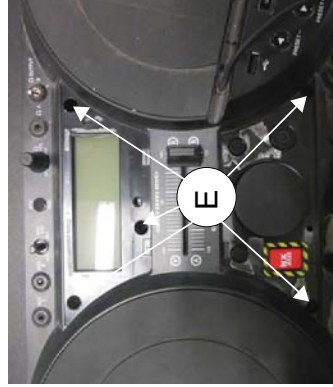

Figure 4

**Dismantling of the Bluetooth A/B Boards**

- 1) Loosen 2\*2 screws "F" on both side A & B as shown in figure 5.

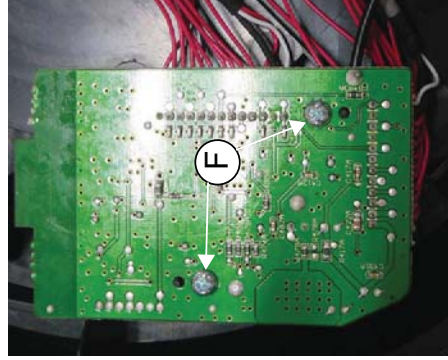

Figure 5

**Dismantling of the KEY&VOL Boards assembly**

- 1) Loosen 5 screws "G" on the top of Key & VOL Board as shown in figure 6.

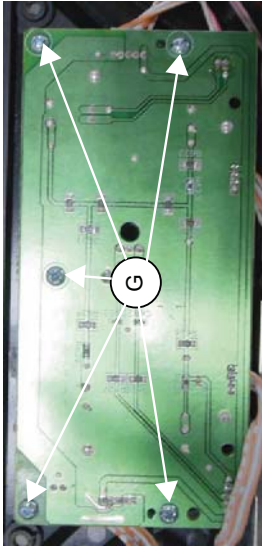

Figure 6

**Dismantling of the MIC Jack Boards assembly**

- 1) Loosen 4 screws "H" on the top of MIC Jack Board as shown in figure 7.



Figure 7

**Dismantling of the MAIN Boards assembly**

- 1) Loosen 5 screws "I" on the top of Main Board as shown in figure 8.

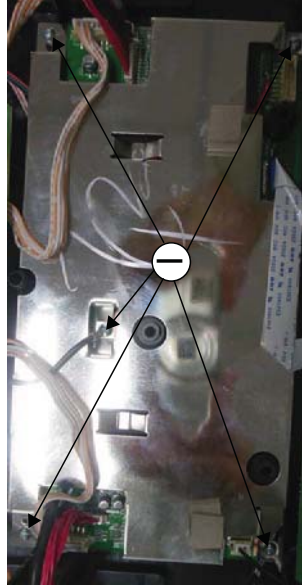

Figure 8

**Dismantling of the Remote Boards assembly**

- 1) Loosen 2 screws "J" on the top of Remote Board as shown in figure 9.

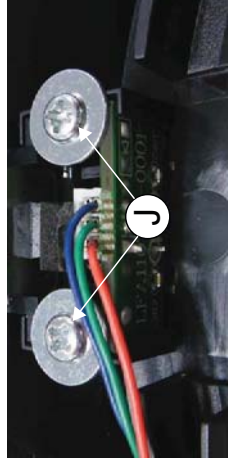

Figure 9

**Dismantling of the MP3 & USB Boards assembly**

- 1) Loosen 3 screws "J" to remove LCD Cover as shown in figure 10.
- 2) Loosen 4'2 screws "K" on the both side A & B of MP3 & USB Board as shown in figure 11.

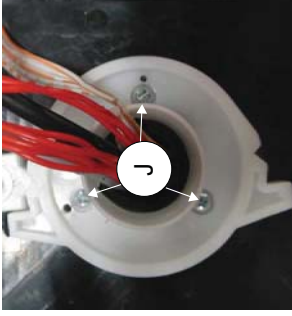

Figure 10



Figure 11

**SERVICE POSITIONS**

**Service A \_AMP&POWER&JACK Boards**



**Service B \_ALL Boards**









IC451A/B INTERNAL IC DIAGRAM - TPS2553DBV

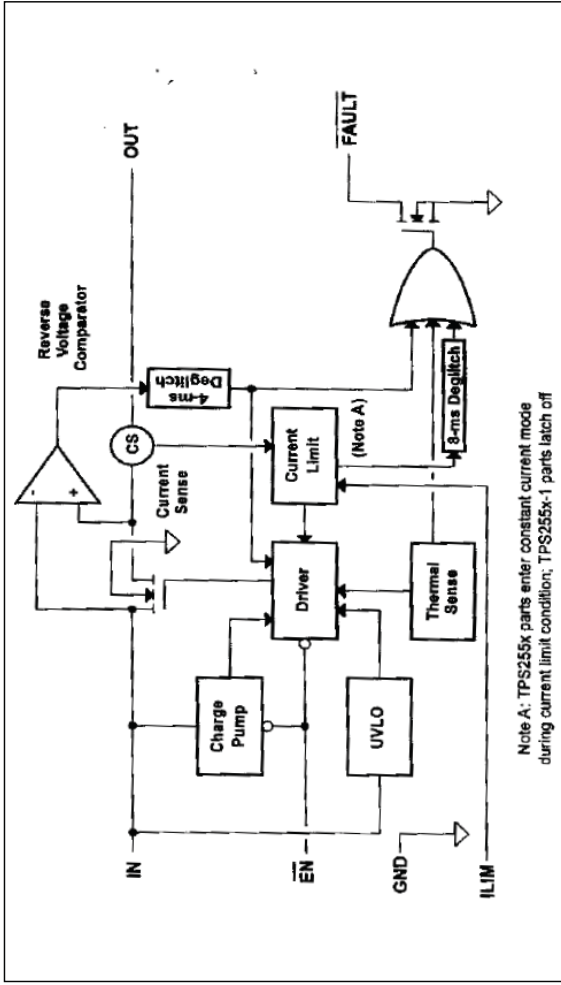

Note A: TPS255x parts enter constant current mode during current limit condition; TPS255x-1 parts latch off

MP3&USB JACK A+B+BT A+B+REMOTE BOARD

TABLE OF CONTENTS

Internal IC Diagram .....7-1  
 Circuit Diagram ..... 7-2  
 Component Layout\_Top View..... 7-3  
 Component Layout\_Bottom View .....7-4

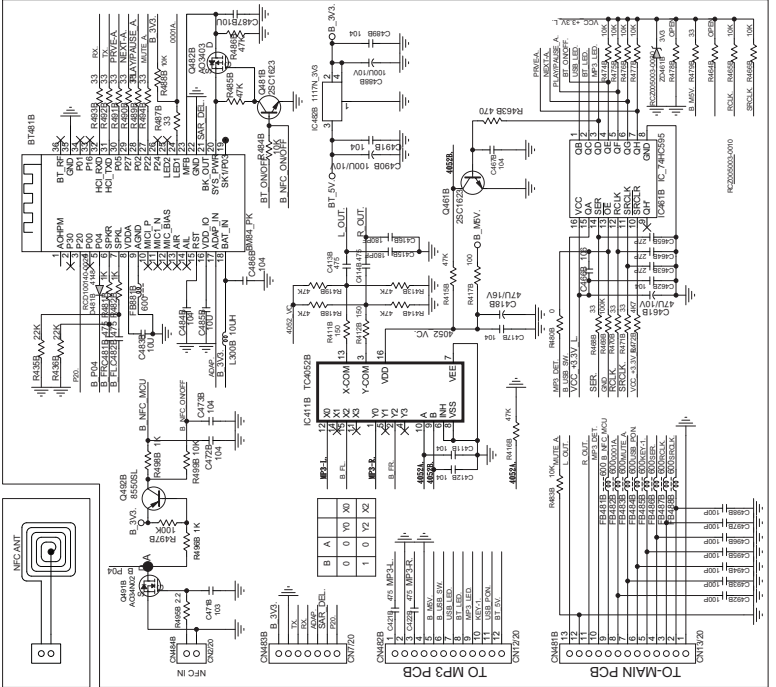
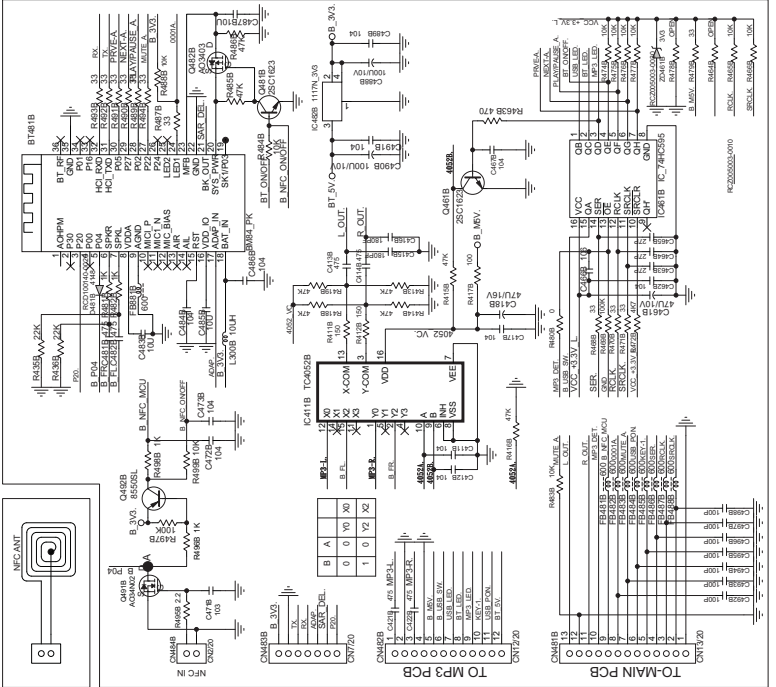
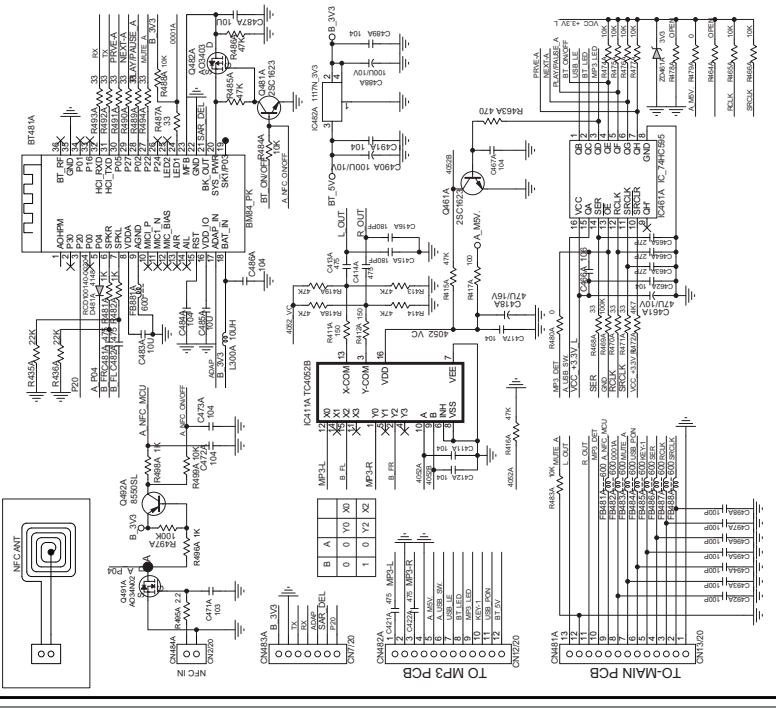
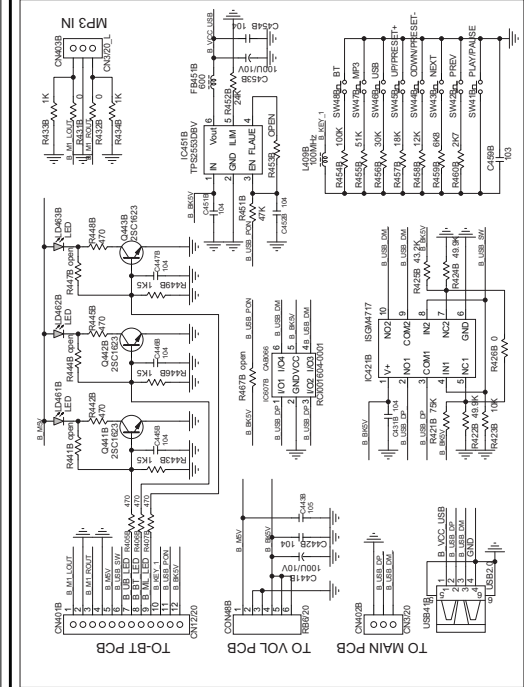
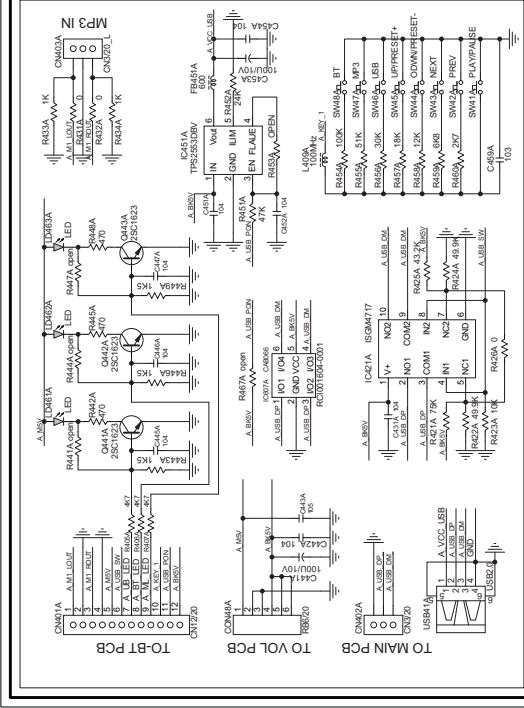

COMPONENT LAYOUT\_TOP View

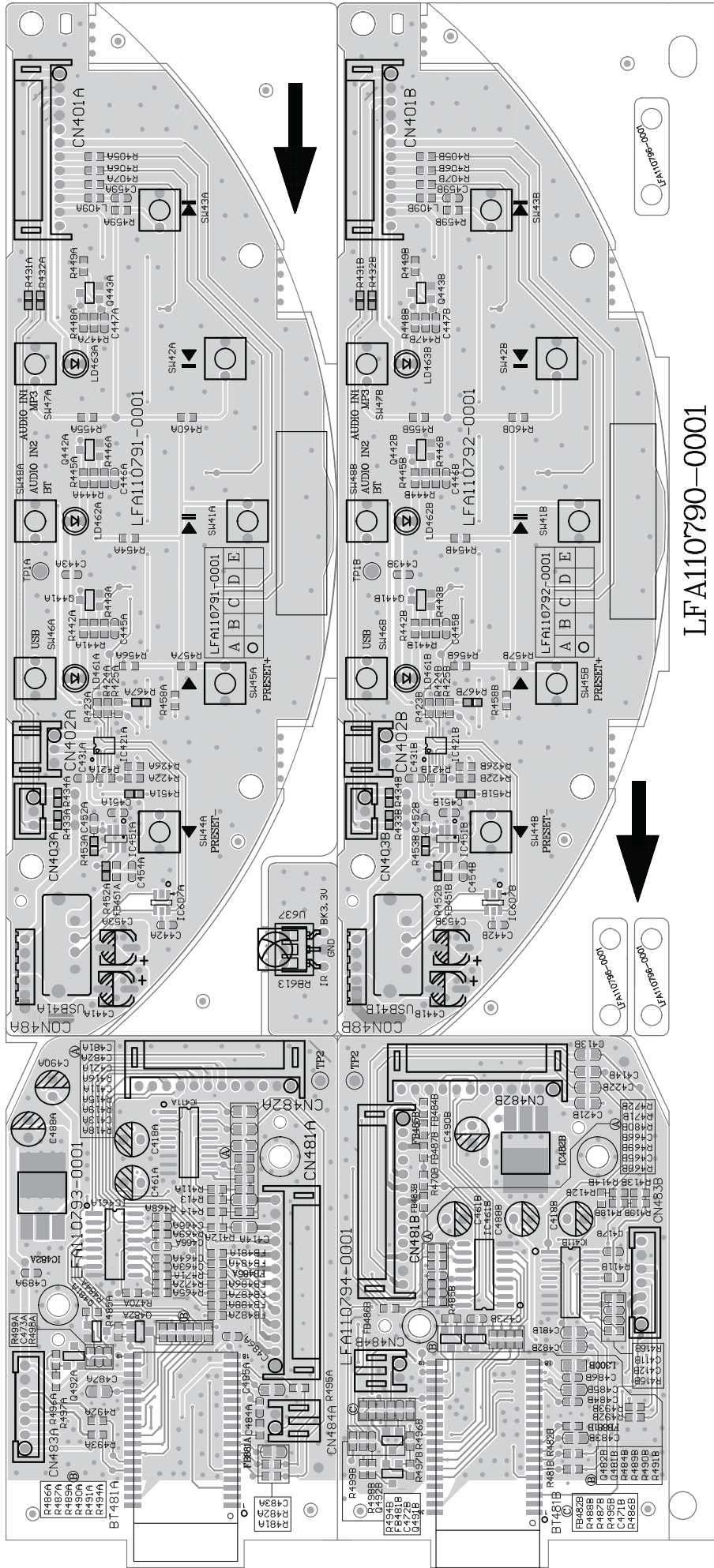



U80 INTERNAL IC DIAGRAM - CS8422-CNZR

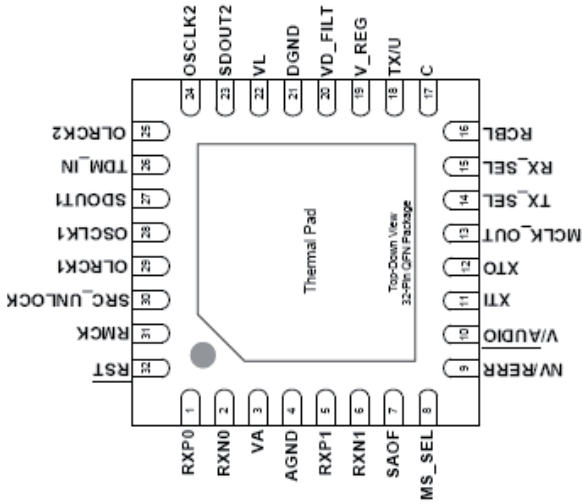

# MAIN BOARD

TABLE OF CONTENTS

- Internal IC Diagram ..... 8-1
- Circuit Diagram(part one) ..... 8-2
- Circuit Diagram(part two) ..... 8-3
- Circuit Diagram(part three) ..... 8-4
- Circuit Diagram(part four) ..... 8-5
- Circuit Diagram(part five) ..... 8-6
- Component Layout\_Top View ..... 8-7
- Component Layout\_Bottom View ..... 8-8

U18 INTERNAL IC DIAGRAM - EM638165TS

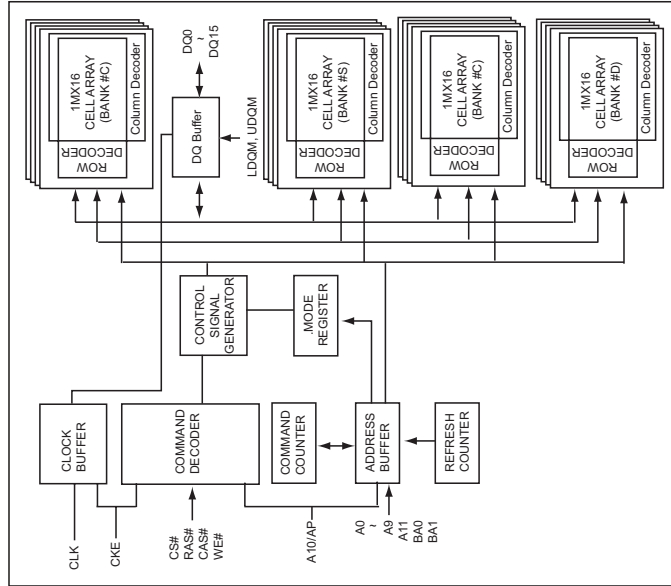





CIRCUIT DIAGRAM (part two)

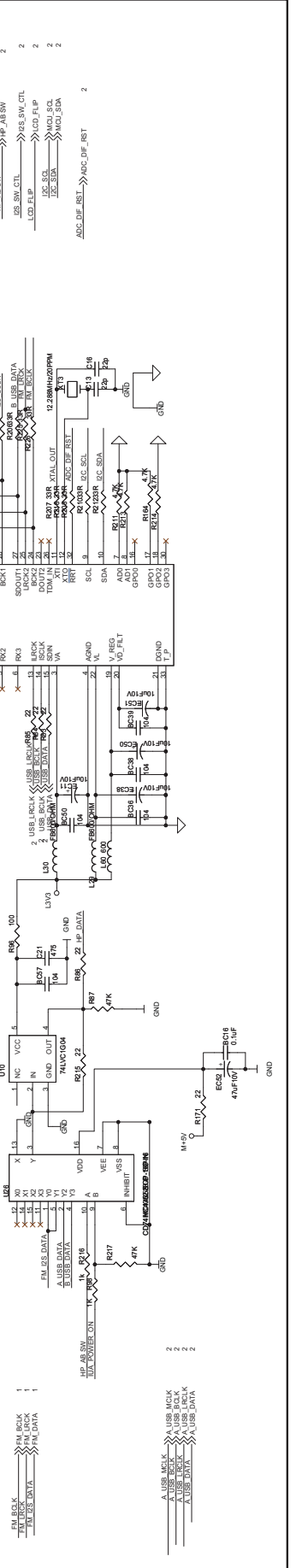
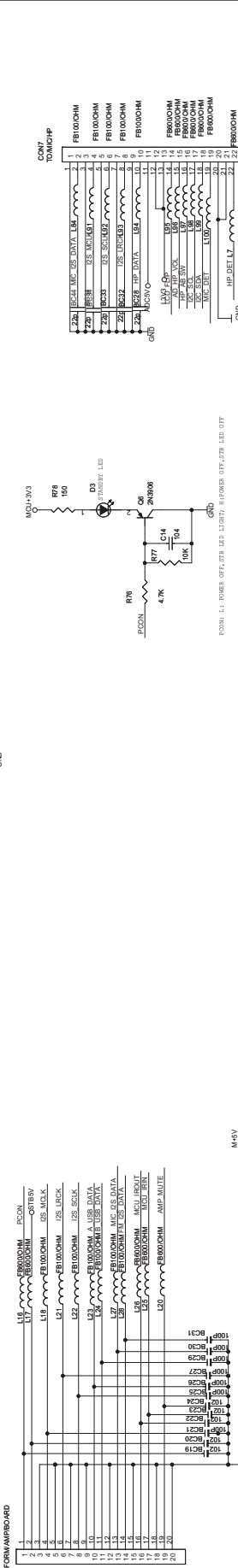
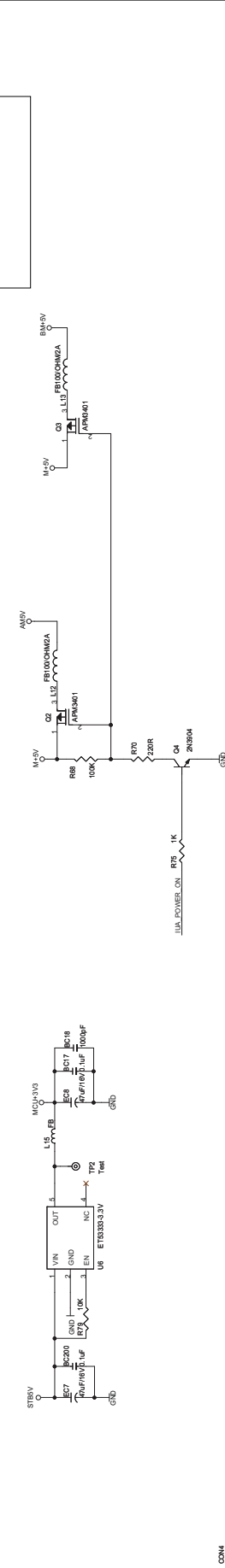
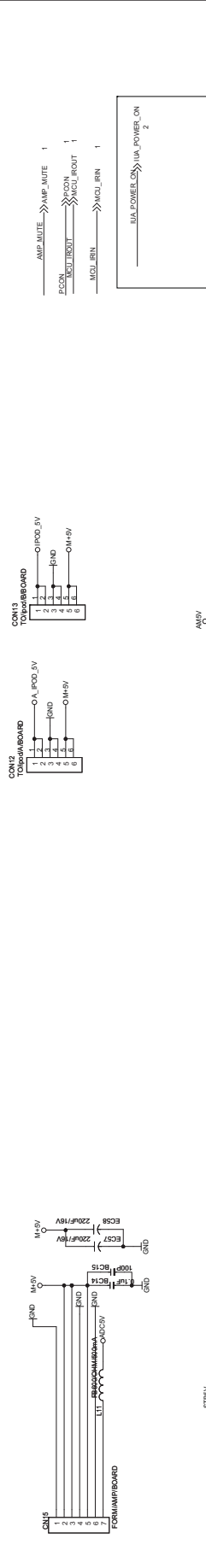

CIRCUIT DIAGRAM (part two)

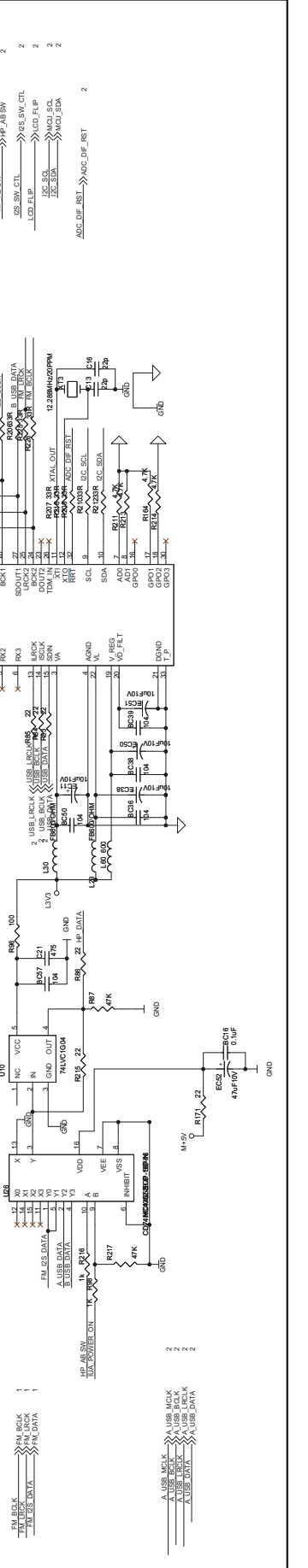
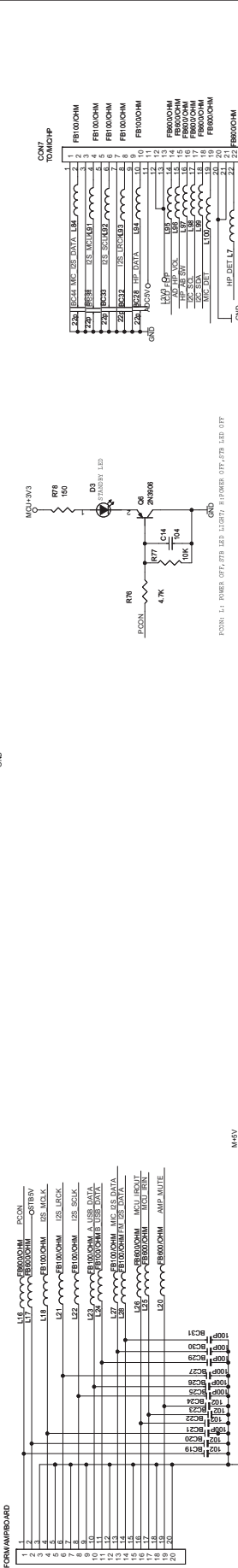
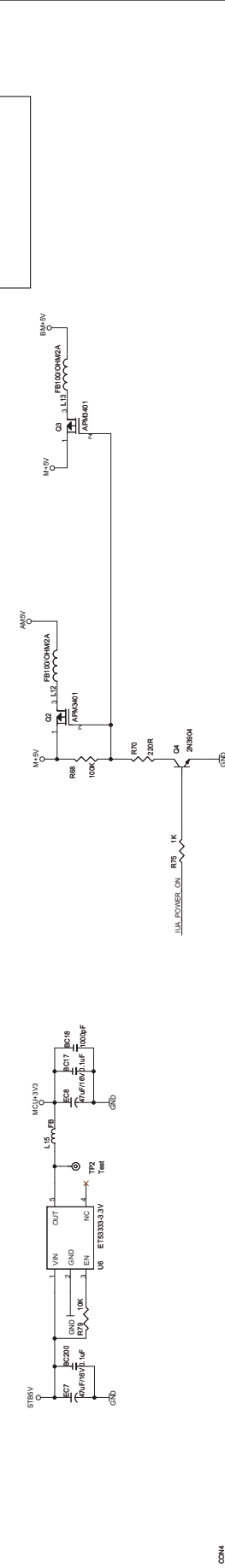
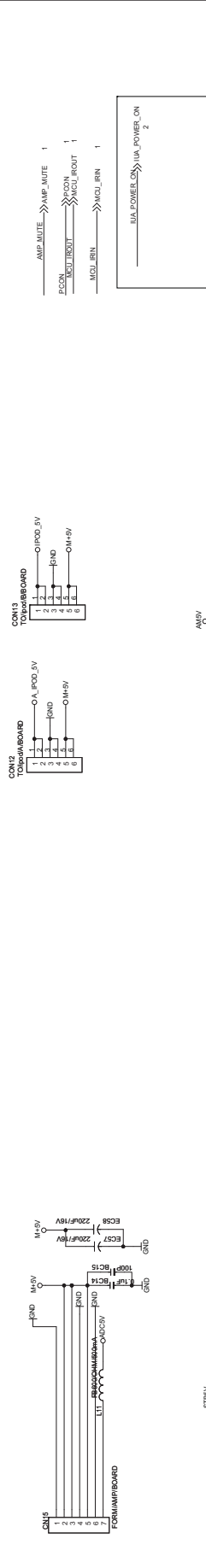

CIRCUIT DIAGRAM (part three)

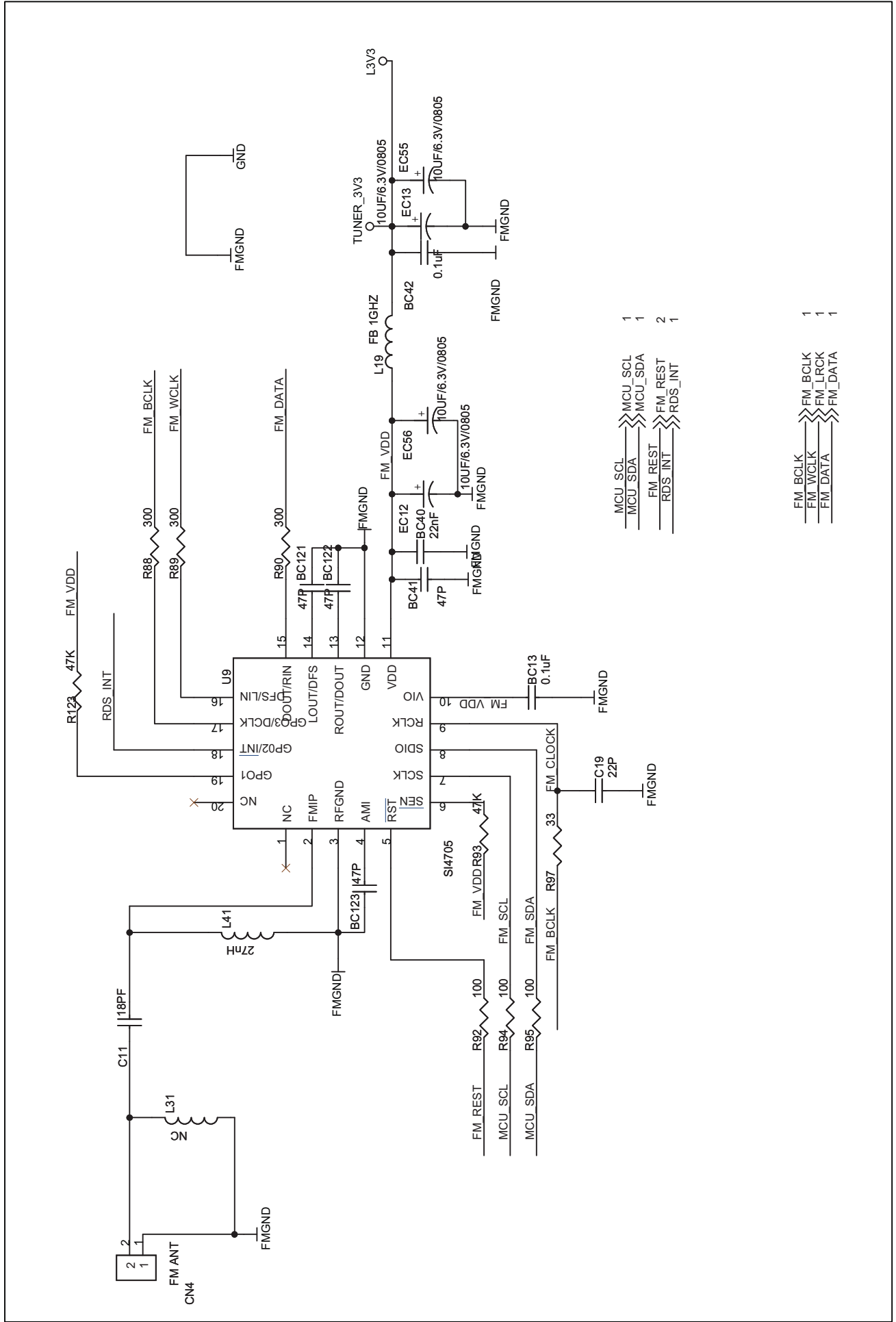

- MCU\_SCL >>> MCU\_SCL 1
- MCU\_SDA >>> MCU\_SDA 1
- FM\_REST >>> FM\_REST 2
- RDS\_INT >>> RDS\_INT 1

- FM\_BCLK >>> FM\_BCLK 1
- FM\_WCLK >>> FM\_WCLK 1
- FM\_LRCK >>> FM\_LRCK 1
- FM\_DATA >>> FM\_DATA 1

CIRCUIT DIAGRAM (part four)

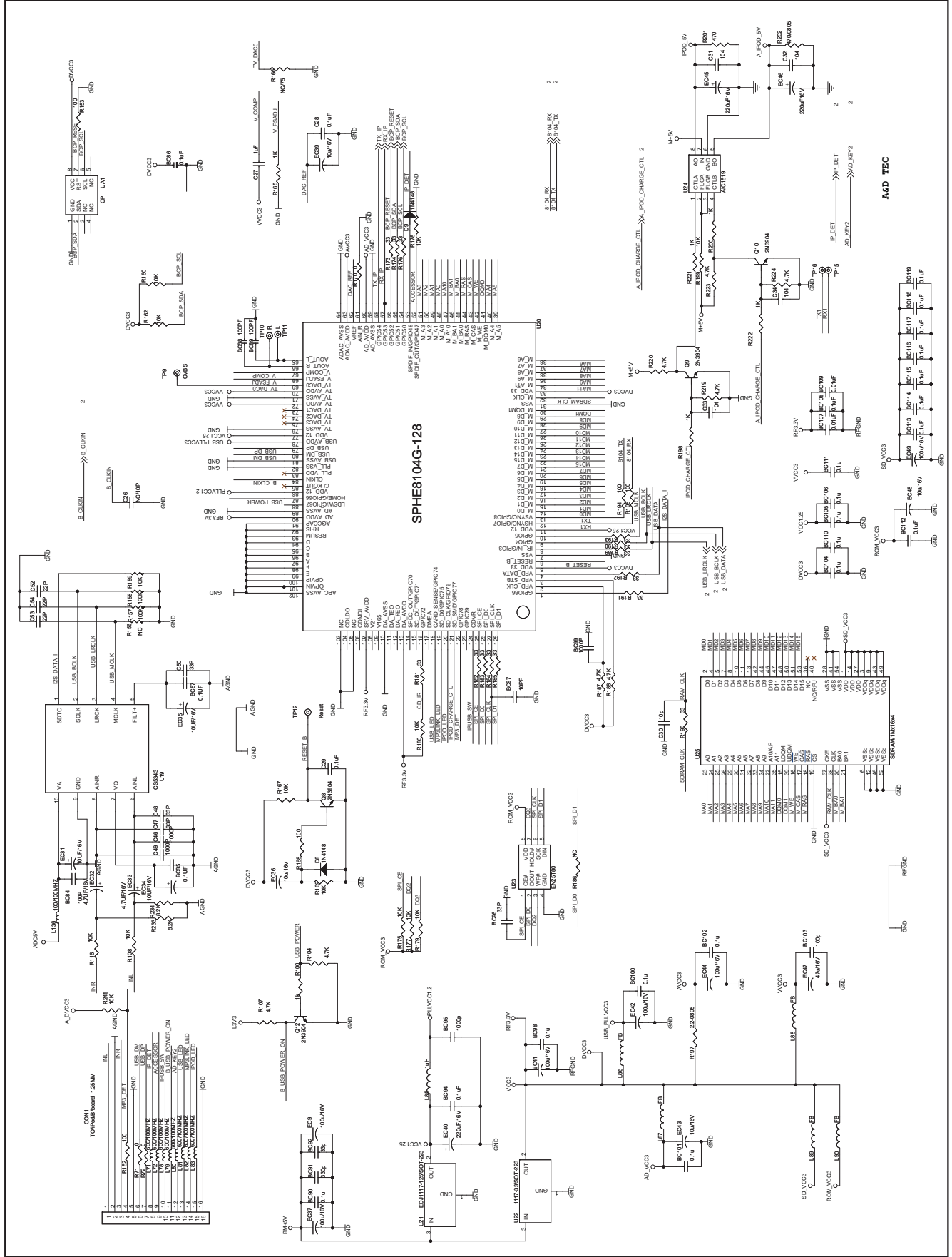

CIRCUIT DIAGRAM (part five)

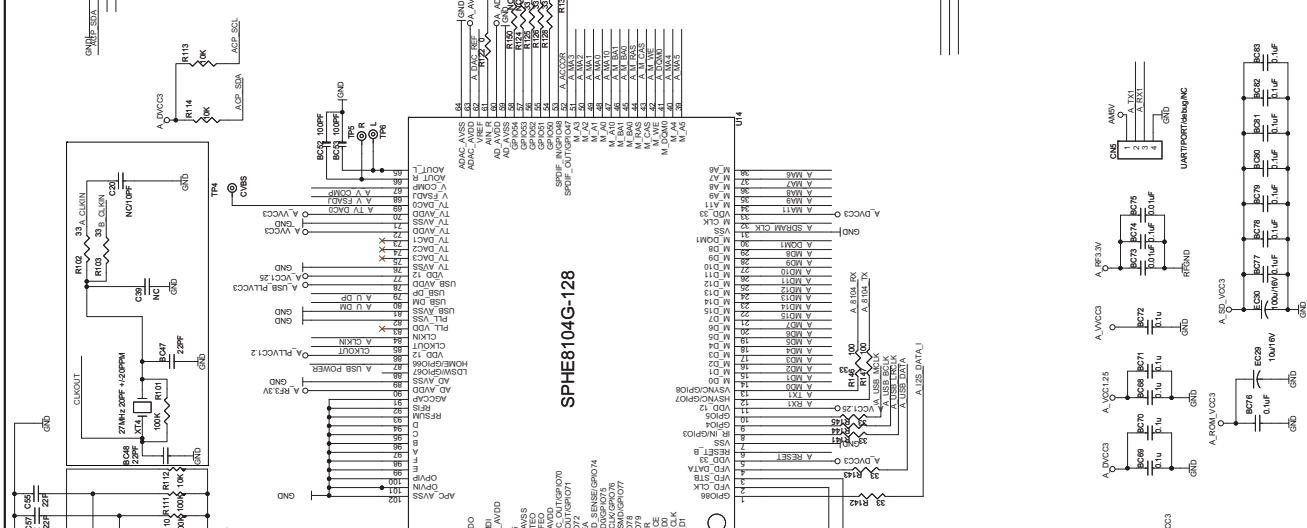
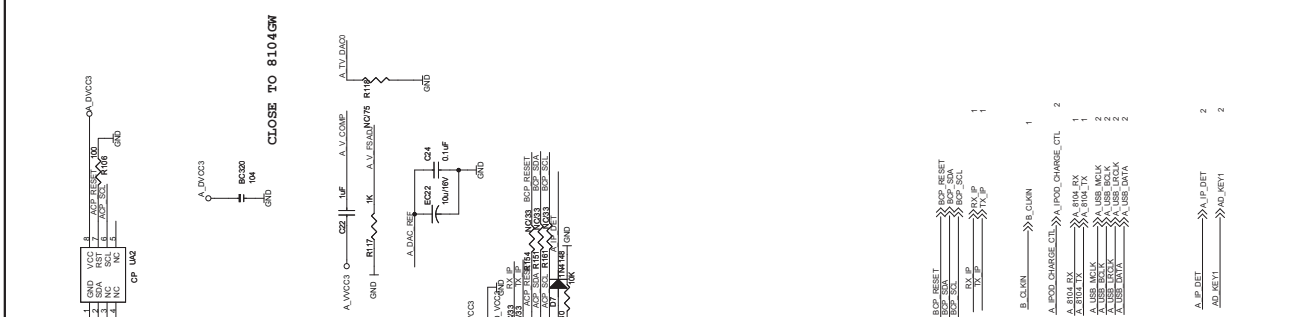
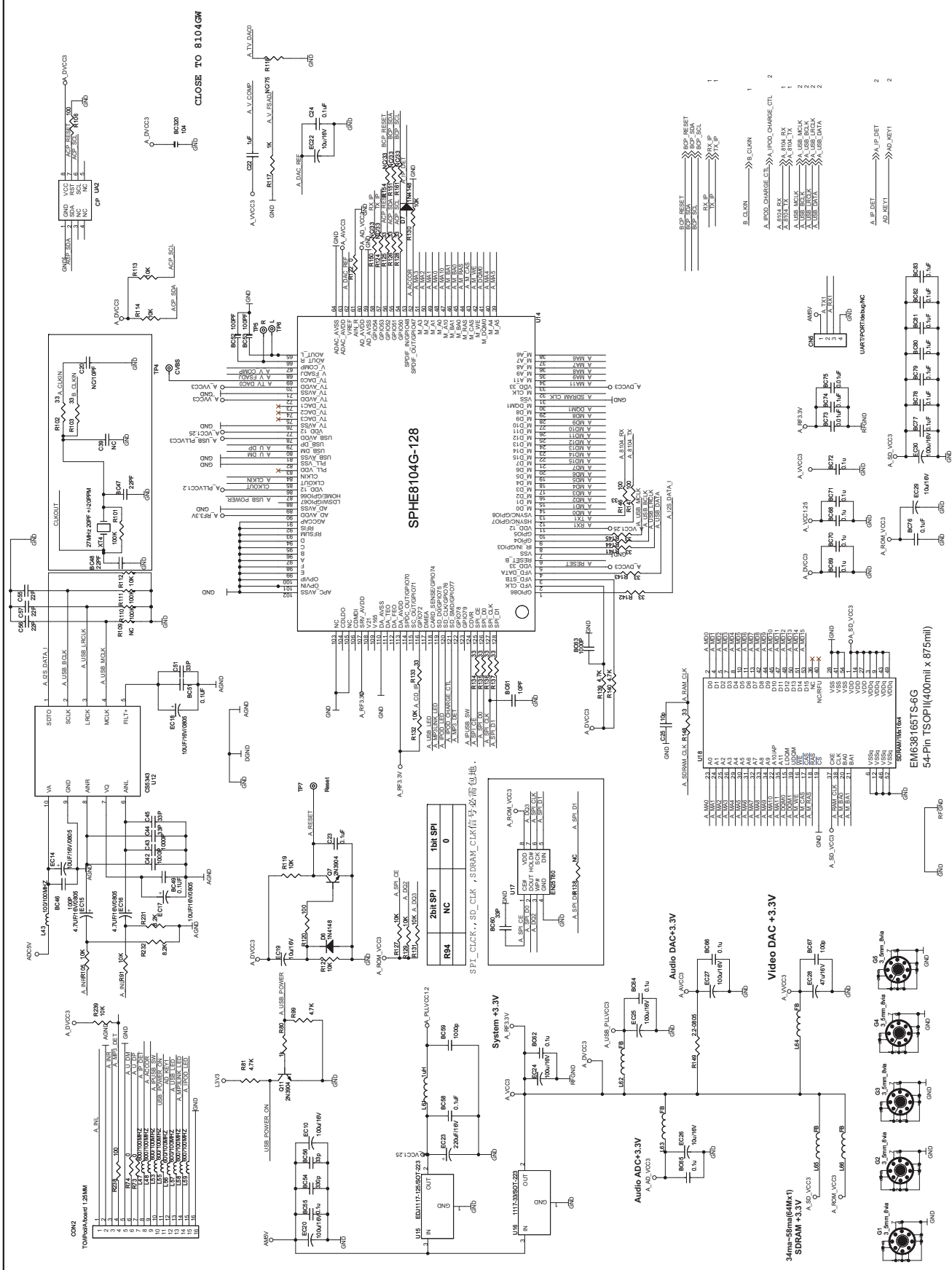

Component Layout\_ Top View

LFM205290-0001  
REV:B Week13. 2012

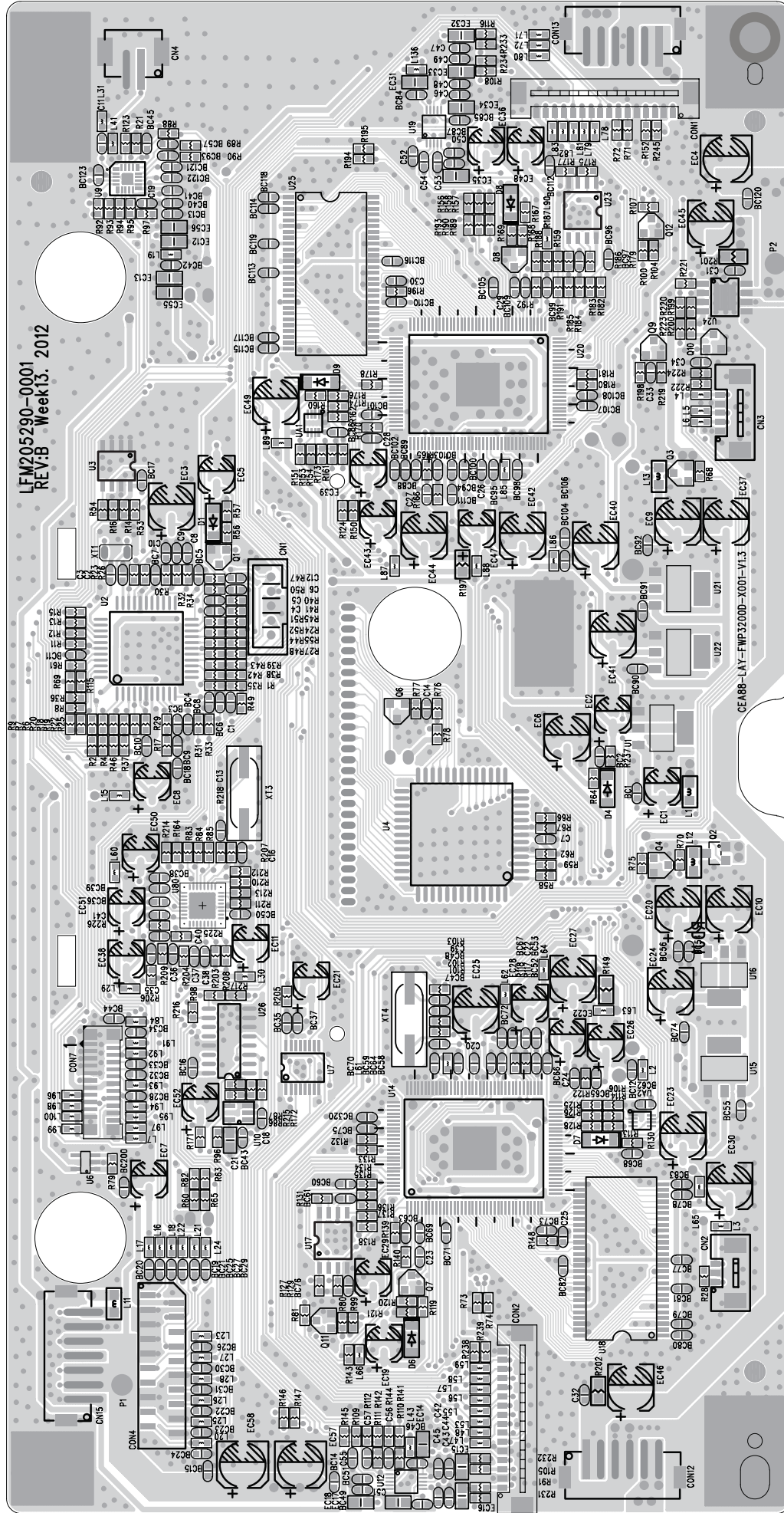

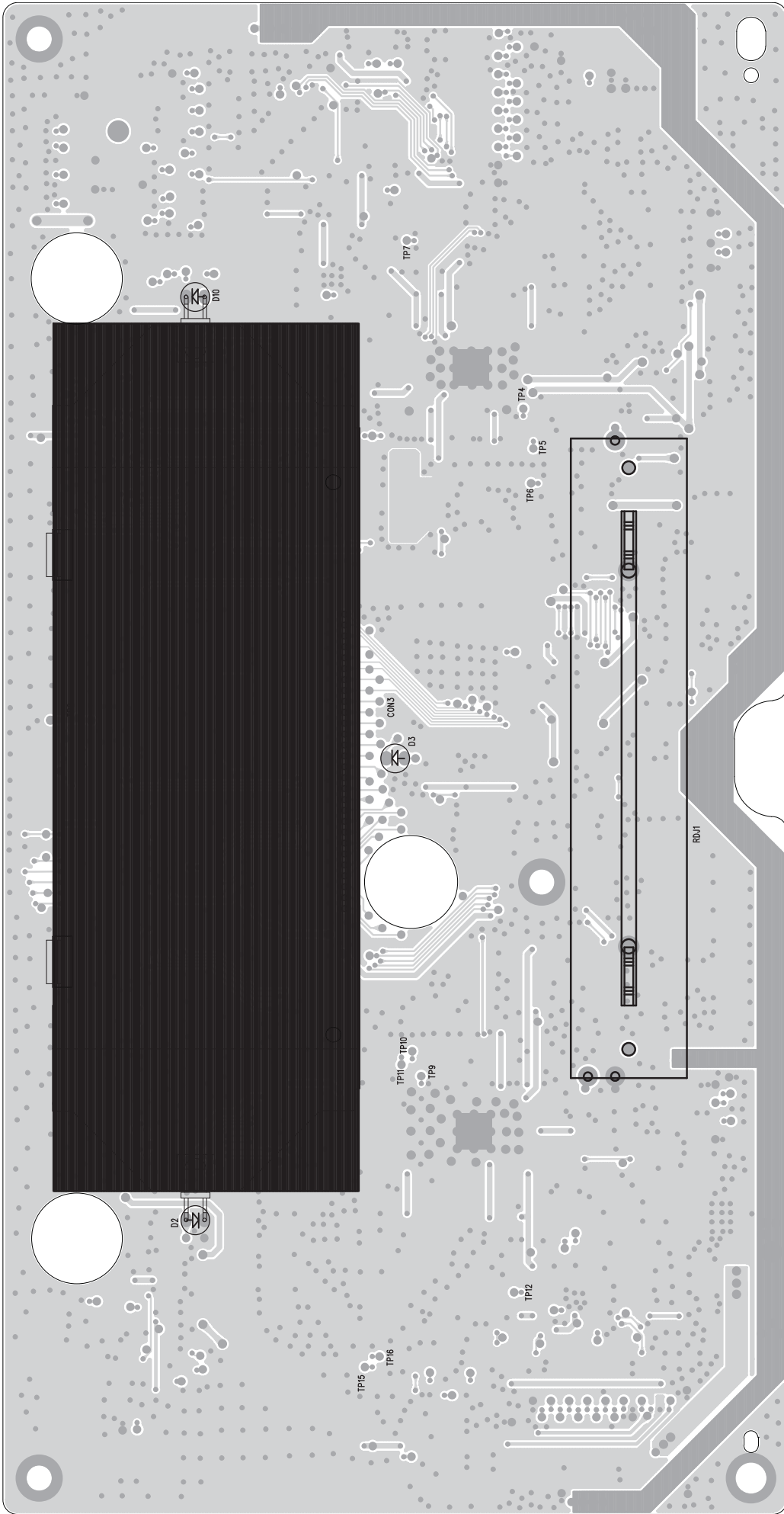

---

# VOL&KEY BOARD

---

TABLE OF CONTENTS

Circuit Diagram .....	9-2
Component Layout_Top View .....	9-3
Component Layout_Bottom View .....	9-4





Component Layout\_Top View

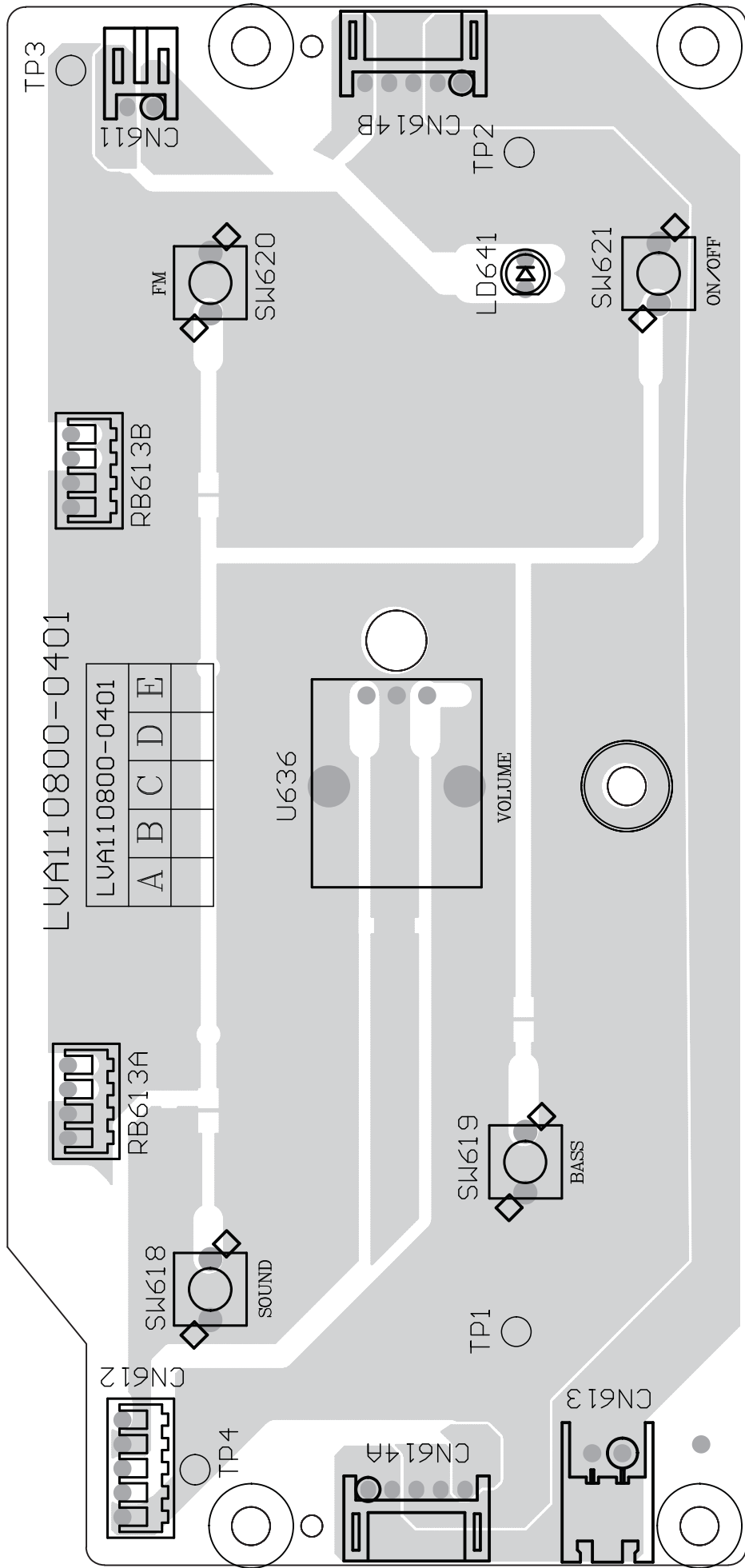

9 - 4

9 - 4

Component Layout\_Bottom View

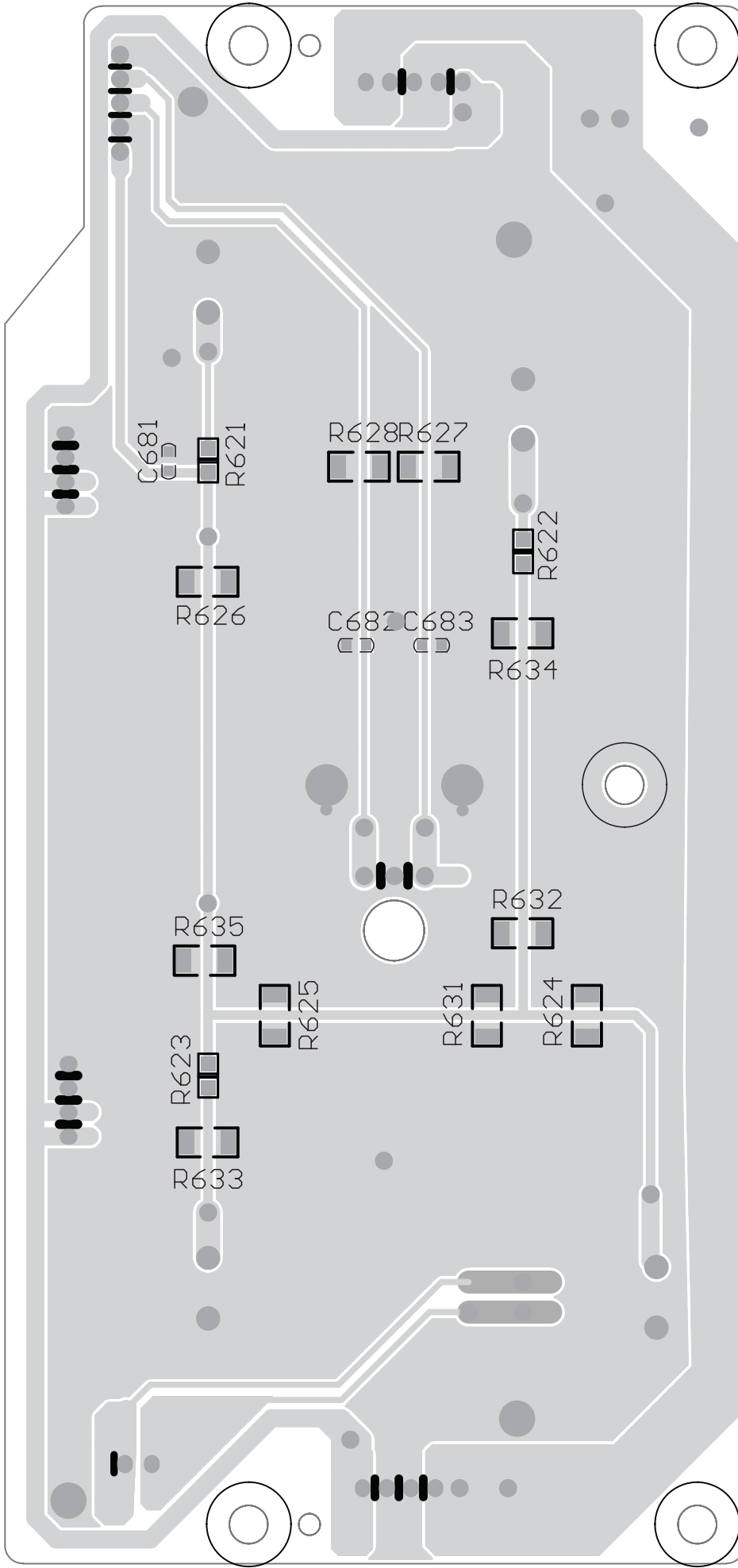

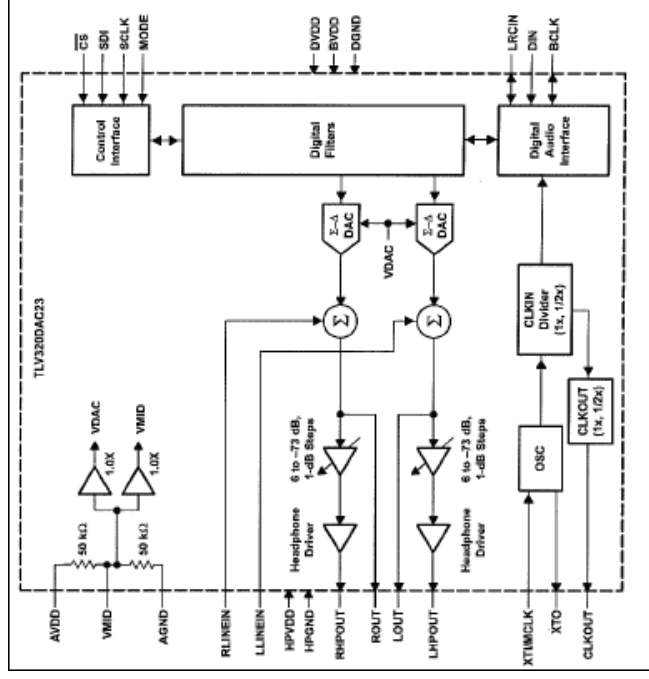

U39 INTERNAL IC DIAGRAM -CS5343-CZZ

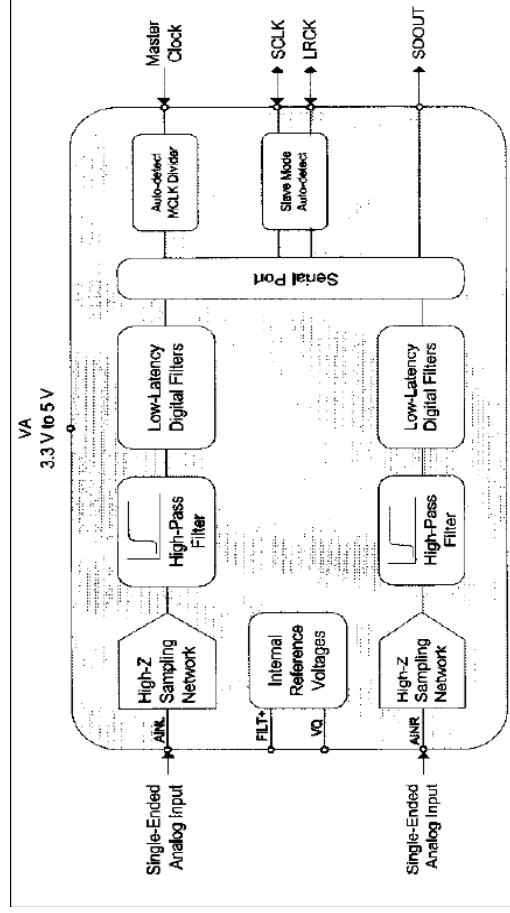

# MIC JACK BOARD

## TABLE OF CONTENTS

Internal IC Diagram	10-1
Circuit Diagram	10-2
Component Layout_Top & Bottom View	10-3

CIRCUIT DIAGRAM

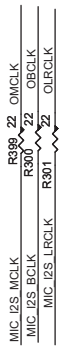
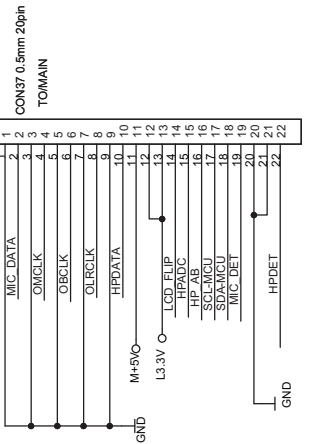
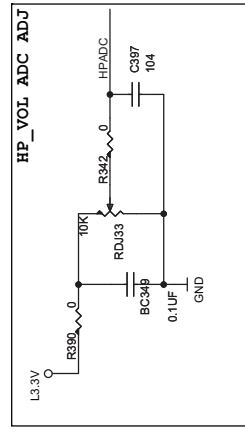
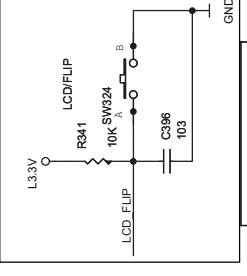
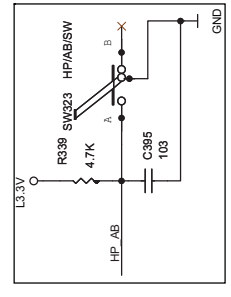
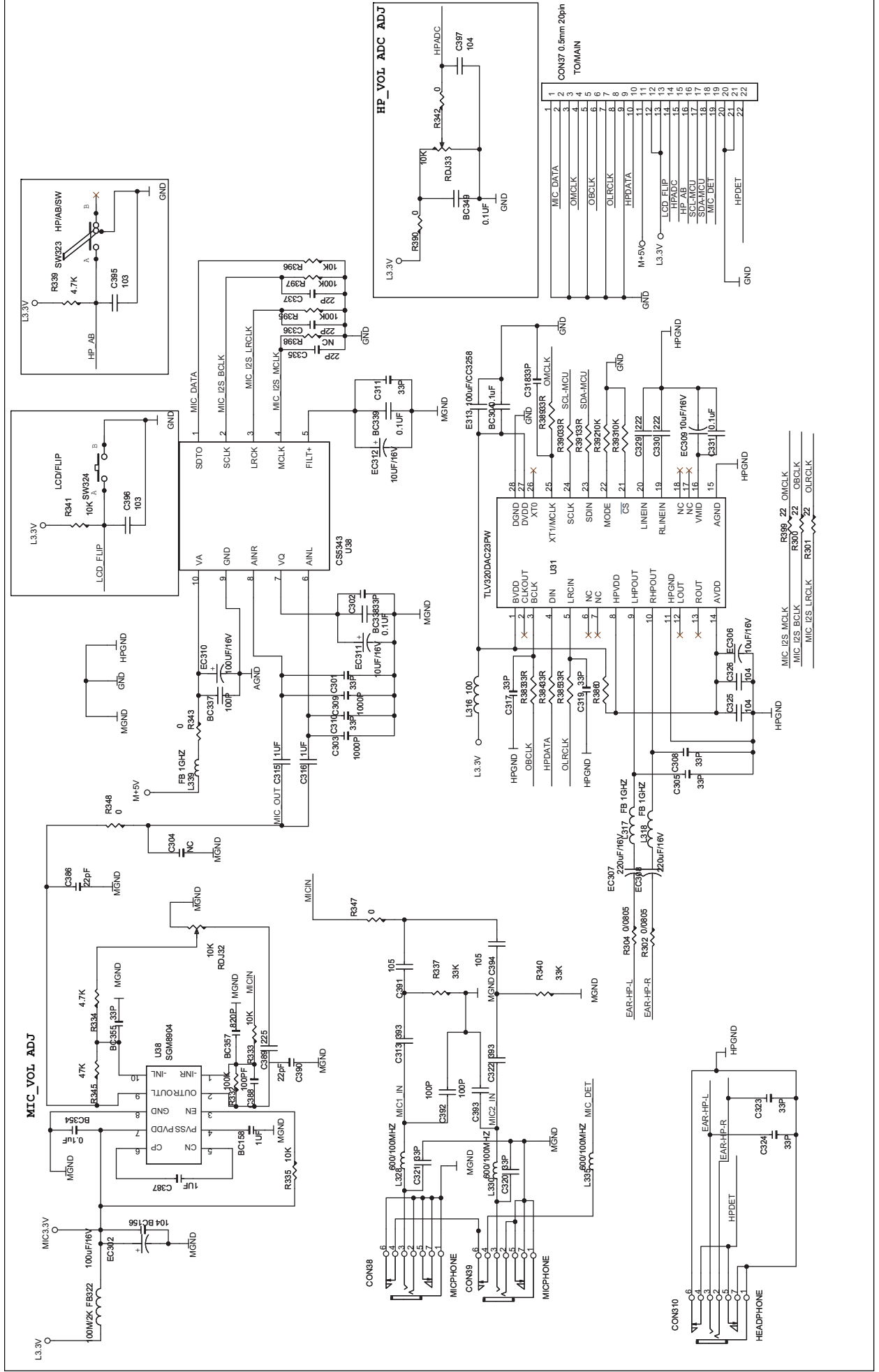



---

---

# JACK BOARD

---

---

TABLE OF CONTENTS

Circuit Diagram ..... 11-2  
Component Layout\_Top & Bottom View..... 11-3

CIRCUIT DIAGRAM

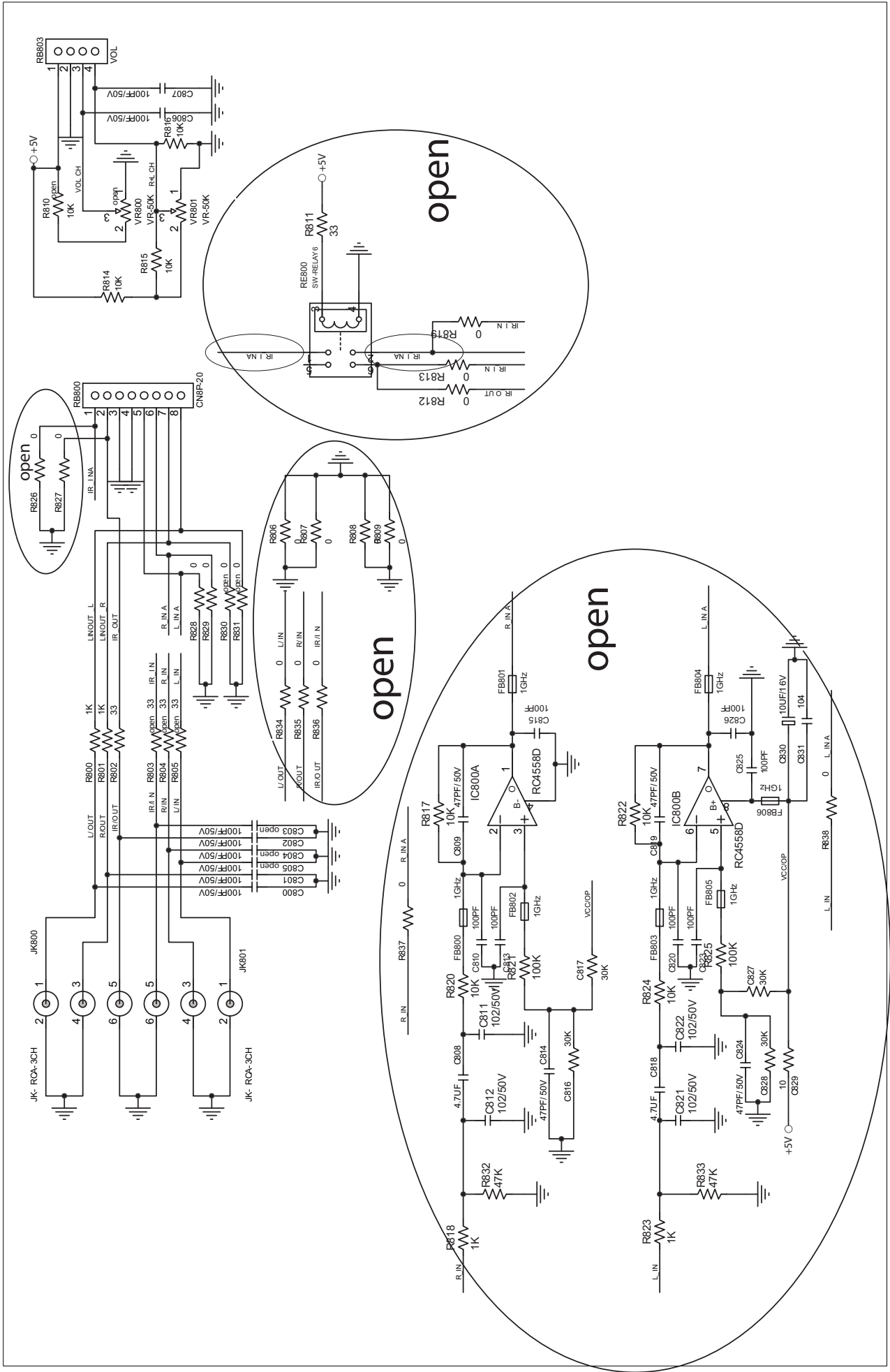





IC301 INTERNAL IC DIAGRAM - TAS5538

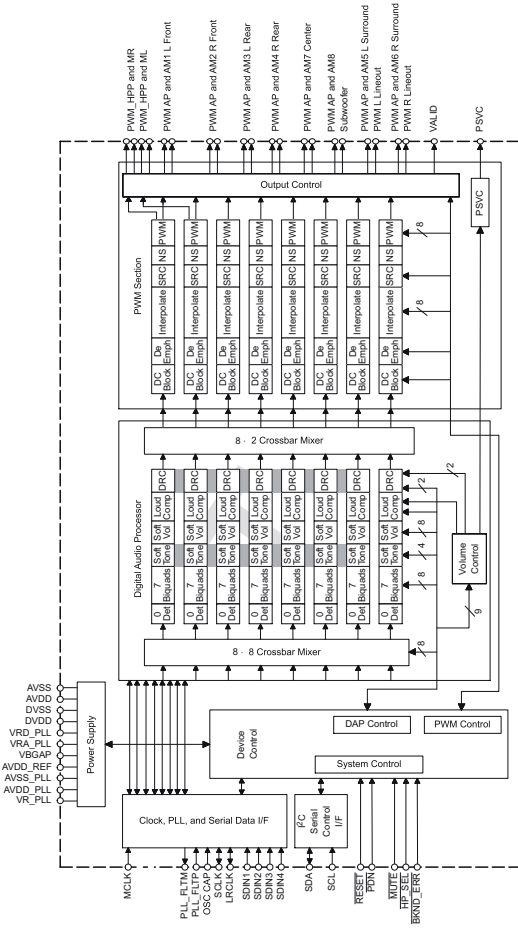

AMP+POWER BOARD

TABLE OF CONTENTS

Internal IC Diagram ..... 12-1  
 Circuit Diagram(part one) ..... 12-2  
 Circuit Diagram(part two) ..... 12-3  
 Circuit Diagram(part three) ..... 12-4  
 Circuit Diagram(part four) ..... 12-5  
 Component Layout\_Top View ..... 12-6  
 Component Layout\_Bottom View ..... 12-7

IC300 INTERNAL IC DIAGRAM - TAS5342ADDV

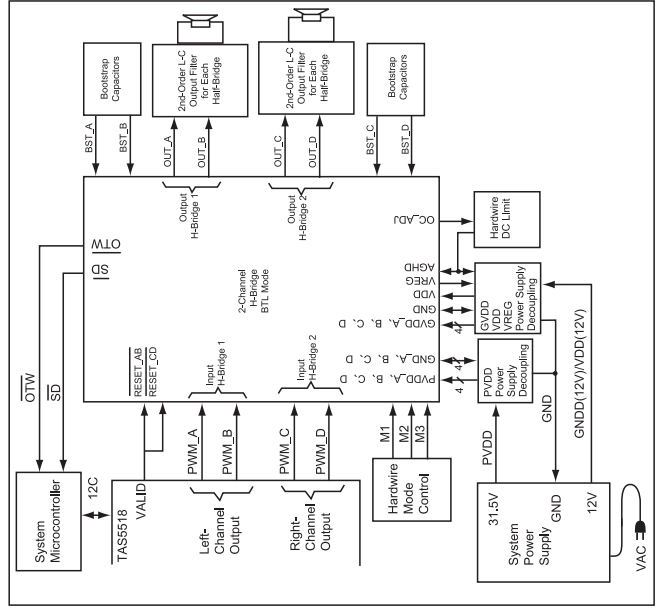

CIRCUIT DIAGRAM(Part one)

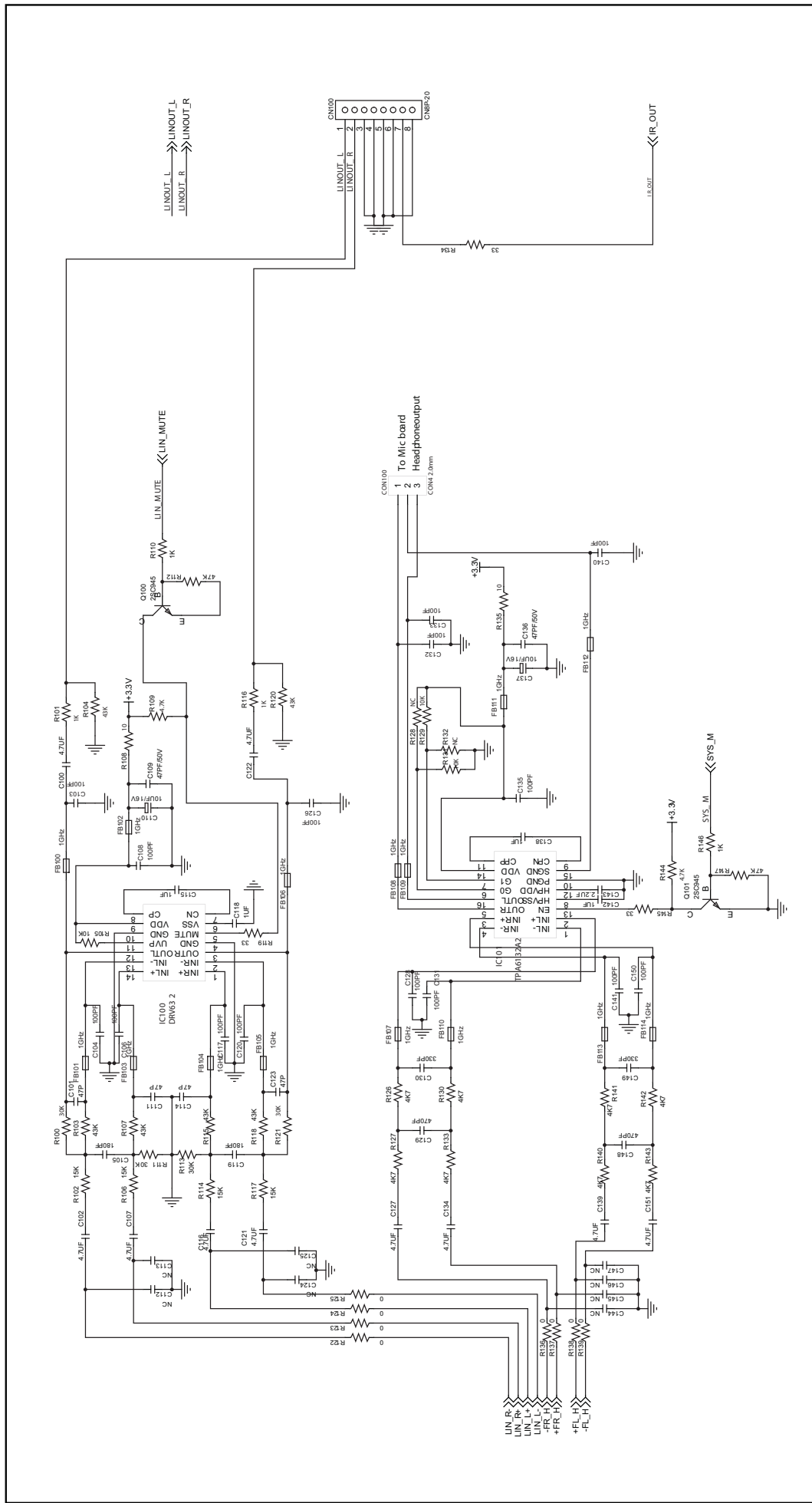



CIRCUIT DIAGRAM(Part three)

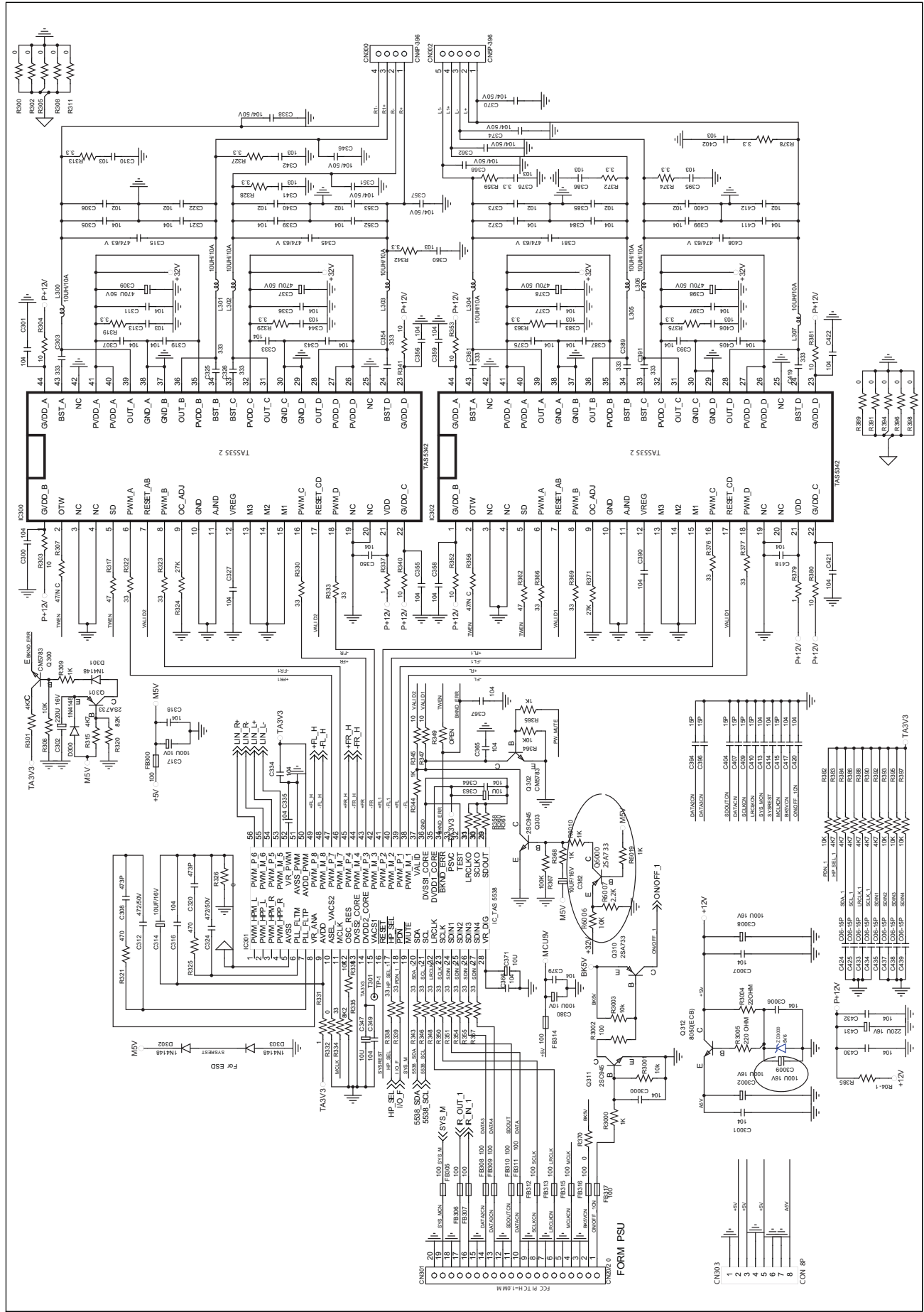

CIRCUIT DIAGRAM(Part four)

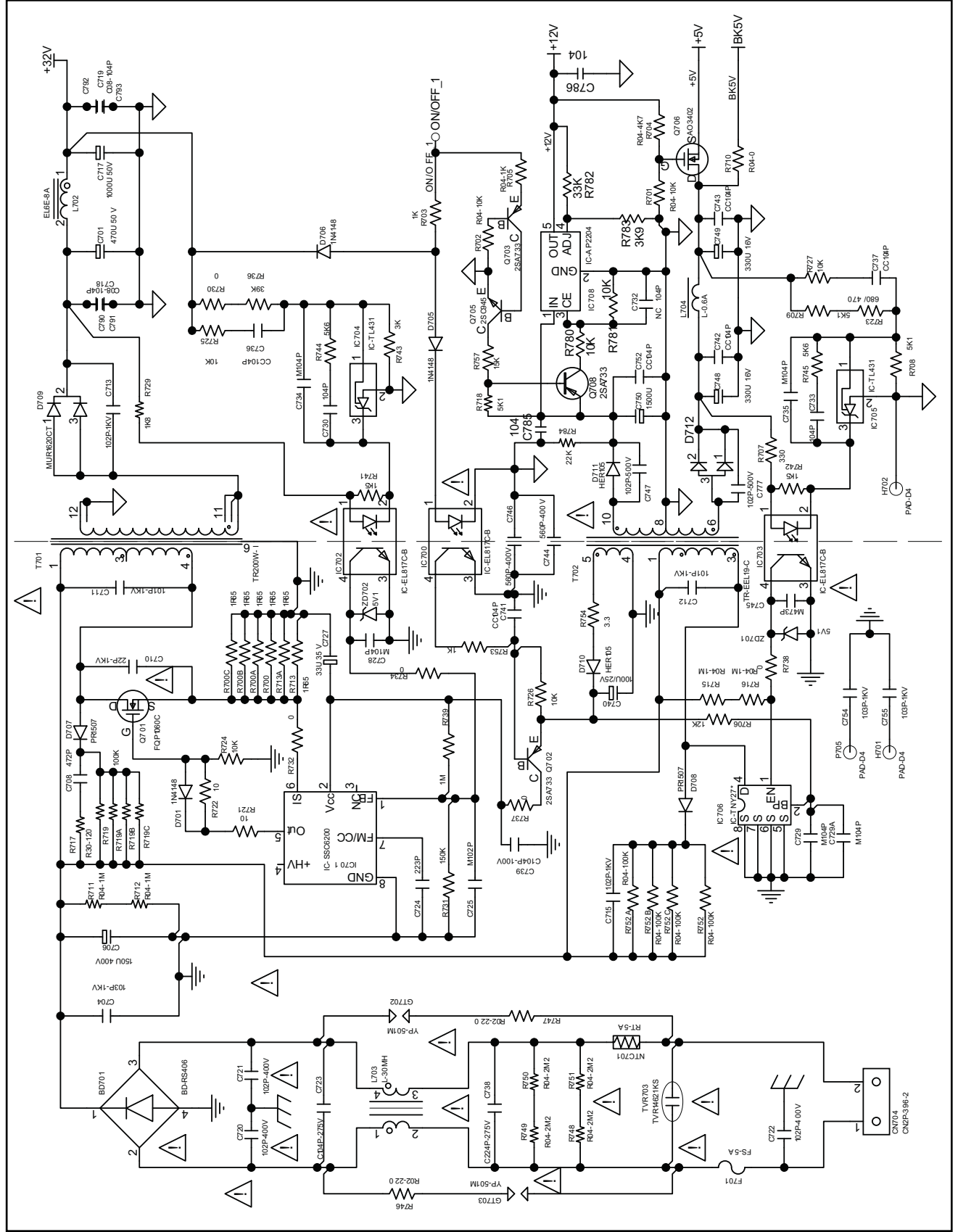

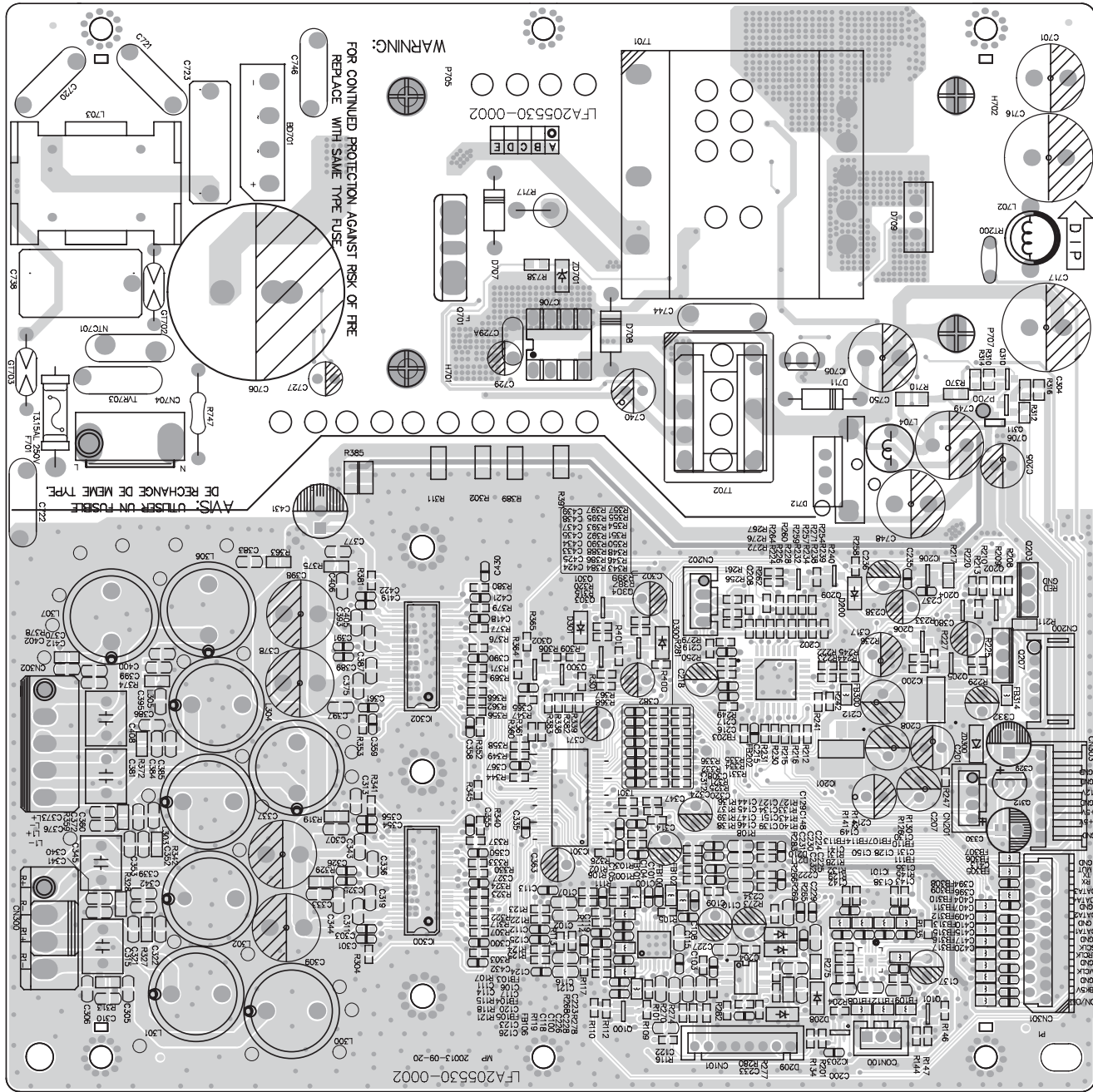

COMPONENT LAYOUT\_Bottom View

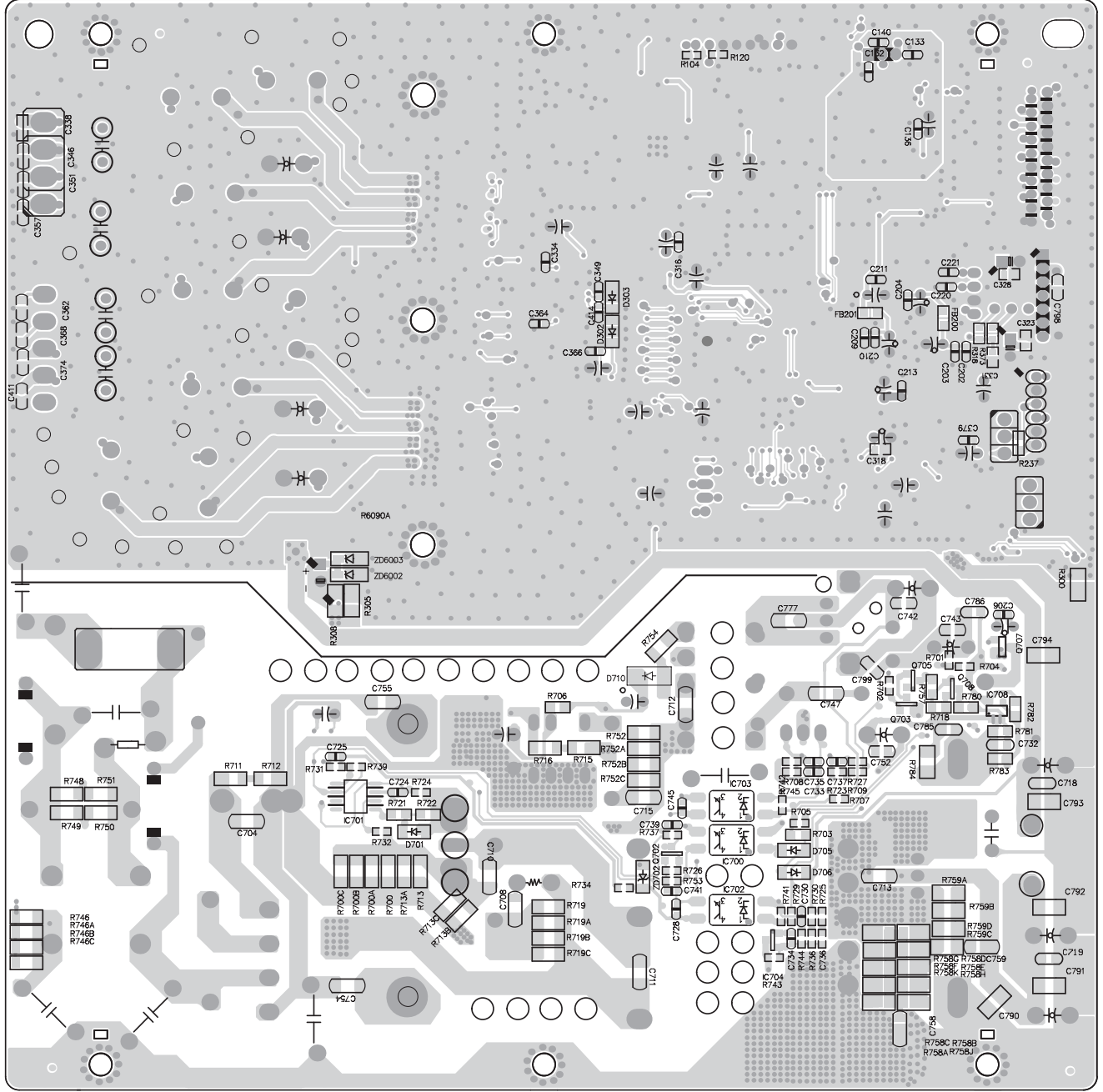

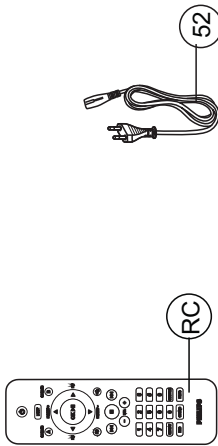
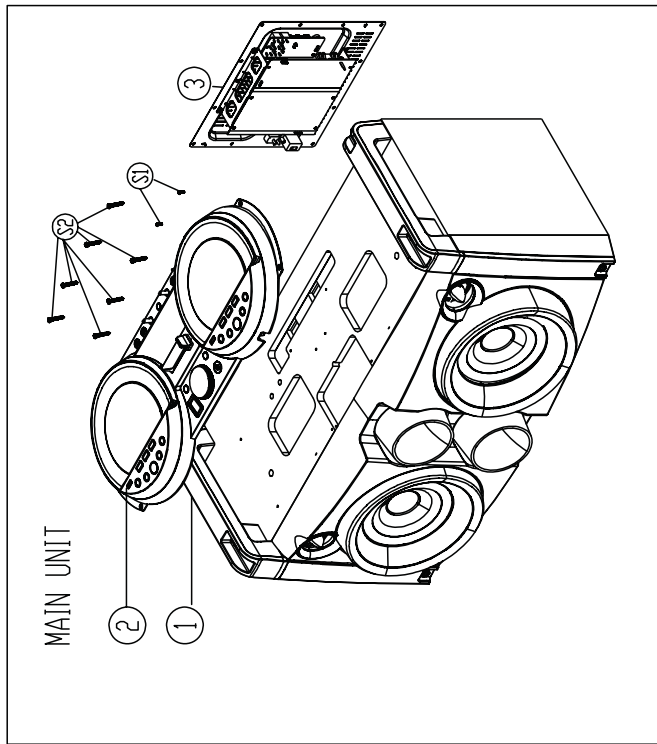

Note: A1=13+20+25+26+27

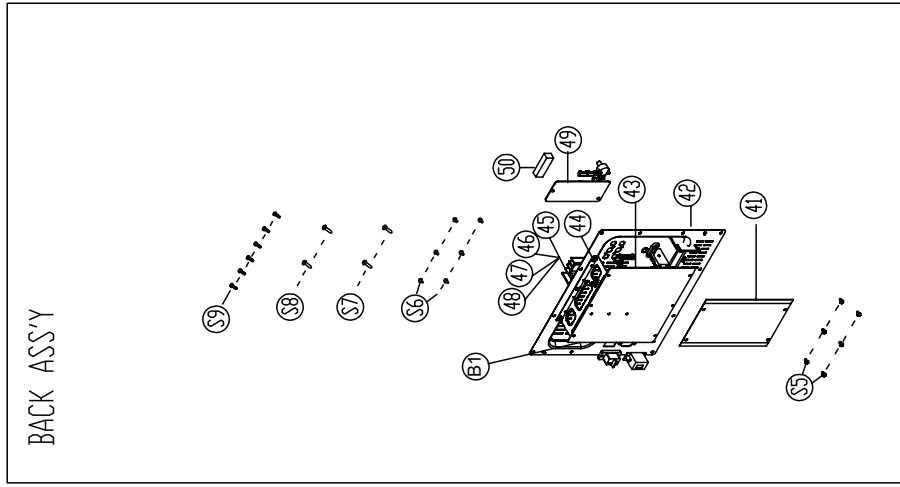
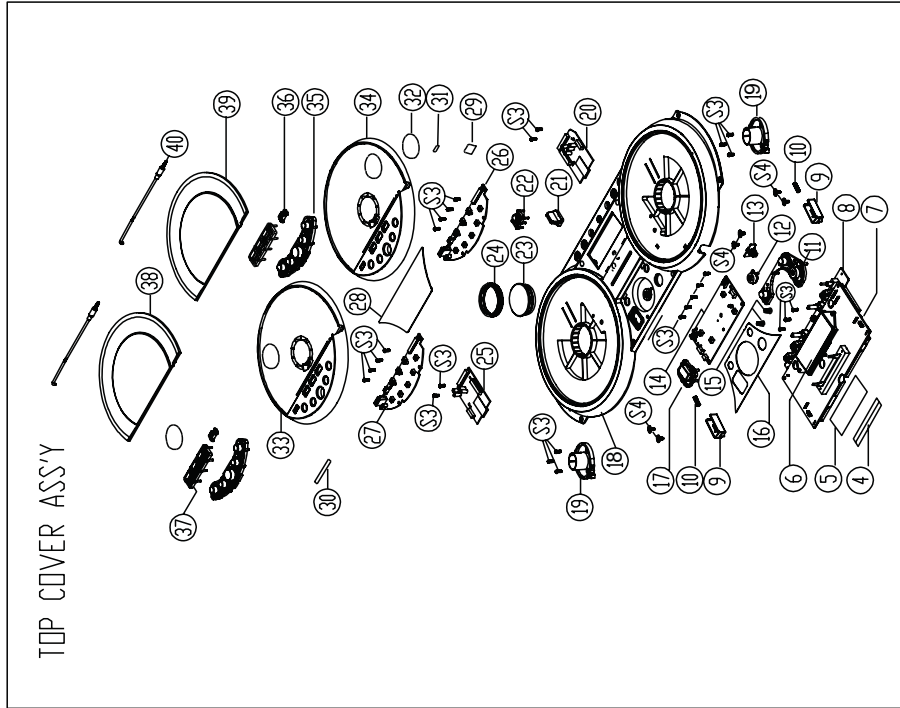



# REVISION LIST

Version 1.0  
\*Initial release